

**FOR YOUR SAFETY**

*If you smell gas:*

1. Open windows.
2. **DO NOT** try to light any appliance.
3. **DO NOT** use electrical switches.
4. **DO NOT** use any telephone in your building.
5. Leave the building.
6. Immediately call your local gas supplier after leaving the building. Follow the gas supplier's instructions.
7. If you cannot reach your gas supplier, call the Fire Department.

**⚠ WARNING**



Fire Hazard

Do not store or use gasoline or other flammable vapors and liquids in the vicinity of this or any other appliance.

Some objects can catch fire or explode when placed close to heater.

Failure to follow these instructions can result in death, injury or property damage.



# Combat®

## UHA-Series Tubular Unit Heaters (Low Profile Range) Installation, Operation & Service Manual

Models UHA[X][S]  
30, 45, 60, 75, 100, 125



**⚠ WARNING**

Improper installation, adjustment, alteration, service or maintenance can result in death, injury or property damage. Read the Installation, Operation and Service Manual thoroughly before installing or servicing this equipment.

Installation must be done by a contractor qualified in the installation and service of gas-fired heating equipment or your gas supplier.

**Installer**

Please take the time to read and understand these instructions prior to any installation. Installer must give a copy of this manual to the owner.

**Owner**

Keep this manual in a safe place in order to provide your serviceman with necessary information.

**Roberts-Gordon LLC**

1250 William Street  
P.O. Box 44  
Buffalo, New York 14240-0044  
Telephone: 716.852.4400  
Fax: 716.852.0854  
Toll Free: 800.828.7450

[www.rg-inc.com](http://www.rg-inc.com)



*Quality in Any Language™*



## TABLE OF CONTENTS

<b>SECTION 1: Heater Safety</b> .....	<b>1</b>	<b>SECTION 10: Operation and Maintenance</b> .....	<b>29</b>
1.1 Manpower Requirements .....	1	10.1 Pre-Start-Up Checks .....	29
1.2 Safety Labels and Their Placement .....	1	10.2 Begin Start-Up .....	29
<b>SECTION 2: Installer Responsibility</b> .....	<b>5</b>	10.3 Complete Start-Up .....	32
2.1 Wall Tag .....	5	<b>SECTION 11: User Instructions</b> .....	<b>33</b>
2.2 Corrosive Chemicals.....	5	11.1 User Instructions .....	33
2.3 National Standards and Applicable Codes .....	5	11.2 Heater Operation .....	33
<b>SECTION 3: Critical Considerations</b> .....	<b>6</b>	11.3 Common User Controls.....	33
3.1 Basic Information .....	6	11.4 Lighting Instructions .....	33
3.2 Manufactured Units.....	6	11.5 Simple Troubleshooting.....	34
3.3 Location and Suspension .....	6	<b>SECTION 12: Servicing</b> .....	<b>35</b>
3.4 Minimum Required Installation Clearances .....	6	12.1 Servicing Instructions.....	35
3.5 Clearances to Combustibles .....	6	12.2 Burner Maintenance.....	35
3.6 Ventilation .....	6	12.3 Fan/Motor Assembly Maintenance .....	35
3.7 Gas Supply .....	7	12.4 Heat Exchanger Maintenance .....	35
3.8 Electrical Supply .....	7	12.5 Gas Valve Maintenance .....	35
3.9 Vent.....	7	12.6 Flue Blower .....	35
<b>SECTION 4: National Standards and Applicable Codes</b> .....	<b>8</b>	12.7 Venting and Air Intake Pipe .....	36
4.1 Gas Codes.....	8	12.8 Maintenance Checklist .....	36
4.2 Aircraft Hangars .....	8	<b>SECTION 13: Troubleshooting</b> .....	<b>38</b>
4.3 Parking Structures and Repair Garages.....	8	13.1 General .....	38
4.4 Electrical .....	8	13.2 Troubleshooting For Automatic Ignition	
4.5 Venting.....	8	Burner Systems .....	39
4.6 High Altitude .....	9	13.3 Troubleshooting for Flame Supervision System .....	40
<b>SECTION 5: Major Components</b> .....	<b>10</b>	13.4 Troubleshooting for Gas Valves.....	41
5.1 General .....	10	13.5 Troubleshooting for Flue Blower .....	41
5.2 Shelf Mounting and Suspension.....	10	<b>SECTION 14: Replacement Parts</b> .....	<b>42</b>
5.3 Wall Mounting .....	10	14.1 Gas Valve .....	42
<b>SECTION 6: Venting</b> .....	<b>14</b>	14.2 Burner Compartment .....	43
6.1 Changing Vent and Air Intake Orientation.....	14	14.3 Ignition Electrode and Flame Probe .....	44
6.2 Venting.....	14	14.4 Heat Exchanger .....	45
6.3 Vent Installation .....	14	14.5 Louver and Louver Springs .....	45
6.4 Unvented Operation.....	15	14.6 Flue Blower Vertical Installation .....	46
6.5 Horizontal Venting.....	15	14.7 Pressure Switch.....	47
6.6 Vertical Venting .....	16	14.8 Ignition Control .....	47
6.7 Length Requirements .....	16	14.9 Axial Fan/Guard/Motor Assembly.....	47
6.8 Vent Material .....	16	14.10 Limit Switches .....	48
6.9 Replacing an Existing Heater in a Venting System .....	16	<b>SECTION 15: Specifications</b> .....	<b>49</b>
<b>SECTION 7: Air Supply</b> .....	<b>21</b>	15.1 Dimension Data.....	49
7.1 Separated Combustion Installation.....	21	15.2 General Technical Data Table (All Models) .....	50
7.2 Unvented Installation .....	21	15.3 Technical Data Table (All Models) .....	50
7.3 Building Ventilation .....	21	<b>SECTION 16: ROBERTS GORDON® COMBAT®</b>	
7.4 Outside Combustion Air Supply.....	21	<b>UHA-Series Warranty</b> .....	<b>53</b>
<b>SECTION 8: Gas Piping</b> .....	<b>22</b>		
8.1 Connections.....	22		
<b>SECTION 9: Wiring</b> .....	<b>23</b>		
9.1 Positioning Thermostats .....	23		
9.2 Low Voltage Thermostat with One Heater .....	23		
9.3 Multiple Heater Wiring 30 - 45 .....	24		
9.4 Multiple Heater Wiring 60 - 125 .....	25		
9.5 Internal Wiring Diagram .....	26		
9.6 Ladder Wiring Diagram.....	27		
9.7 Electrical Connection to the Heater .....	28		

© 2008 Roberts-Gordon LLC

All rights reserved. No part of this work covered by the copyrights herein may be reproduced or copied in any form or by any means - graphic, electronic, or mechanical, including photocopying, recording, taping or information storage and retrieval systems - without the written permission of Roberts-Gordon LLC.

Printed in U.S.A.

---

---

## TABLE OF FIGURES

Figure 1: UHA 30 - 45 Label Placement .....	2
Figure 2: UHA 60 - 75 Label Placement .....	3
Figure 3: UHA 100 - 125 Label Placement.....	4
Figure 4: Installation Clearances and Clearances to Combustibles .....	7
Figure 5: Suspension Methods .....	11
Figure 6: Shelf-Mounting Methods.....	11
Figure 7: Wall Shelf Mounting and Hanging Suspension.....	12
Figure 8: Vertical Louvers (Optional).....	13
Figure 9: Vent and Roof Detail .....	17
Figure 10: Standard Vented Heater - Vertical and Horizontal Vent Termination .....	17
Figure 11: Standard Vented Heater - Common Vertical Vent Termination.....	18
Figure 12: Separated Combustion Heater - Vertical and Horizontal Vent Termination .....	19
Figure 13: Concentric Vent Box.....	19
Figure 14: Concentric Vertical and Horizontal Vent Termination - Separated Combustion Heater .....	20
Figure 15: Gas Connection .....	22
Figure 16: Automatic Burner Control Sequence.....	30
Figure 17: Gas Valve for Models UHA[X][S] 30 - 45.....	30
Figure 18: Gas Valve for Models UHA[X][S] 60 - 125.....	31
Figure 19: Manual Reset Limit Switch.....	33
Figure 20: LED Diagnostic Codes.....	34



## SECTION 1: HEATER SAFETY



Your Safety is Important to Us!  
This symbol is used throughout the manual to notify you of possible fire, electrical or burn hazards. Please pay special attention when reading and following the warnings in these sections.

Installation, service and annual inspection of heater must be done by a contractor qualified in the installation and service of gas-fired heating equipment.

Read this manual carefully before installation, operation or service of this equipment.

Not all heaters are approved for residential installation. Check the heater's silver rating plate for residential approval status. Heaters that do not have residential approval must not be installed in residential spaces. These instructions, the layout drawing, local codes and ordinances and applicable standards that apply to gas piping, electrical wiring, venting, etc. must be thoroughly understood before proceeding with the installation.

Protective gear is to be worn during installation, operation and service. Thin sheet metal parts, including the various venting components, have sharp edges. To prevent injury, the use of work gloves is recommended.

Before installation, check that the local distribution conditions, nature of gas and pressure and adjustment of the appliance are compatible.

### 1.1 Manpower Requirements

To prevent personal injury and damage to the heater, two persons will be required for installation.

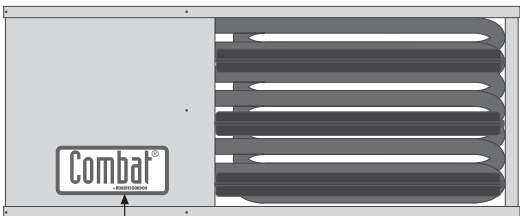
### 1.2 Safety Labels and Their Placement

Product safety signs or labels should be replaced by product user when they are no longer legible.

Please contact Roberts Gordon LLC or your ROBERTS GORDON® independent distributor to obtain replacement signs or labels. See Page 2, Figure 1 through Page 4, Figure 3.

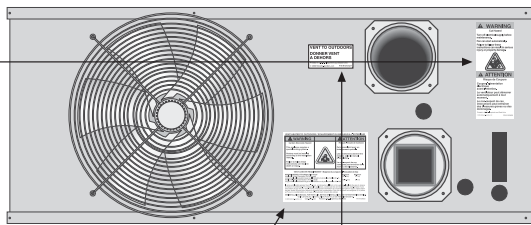
Figure 1: UHA 30 - 45 Label Placement

FRONT VIEW



Logo Label

BACK VIEW



Cut Hazard Label

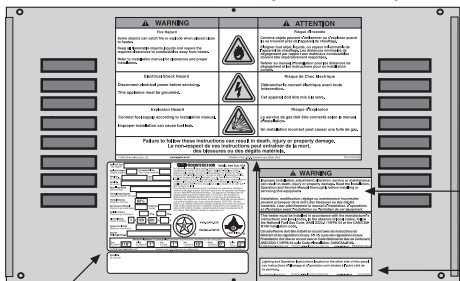


Vent Length Label



Vent to Outdoors Label

ACCESS SIDE VIEW (OUTSIDE)

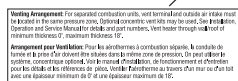
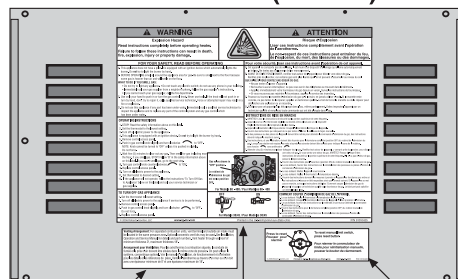


Installation Label

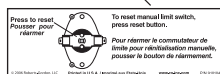
Lighting and Operation Instructions located on the other side of this panel. Les instructions d'allumage et d'opération sont situées à l'autre côté de ce panneau.

Instruction Location Label

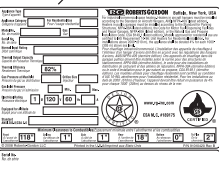
ACCESS SIDE VIEW (INSIDE)



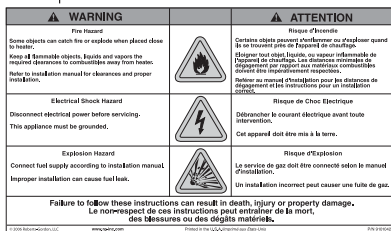
\*Venting Arrangement Label



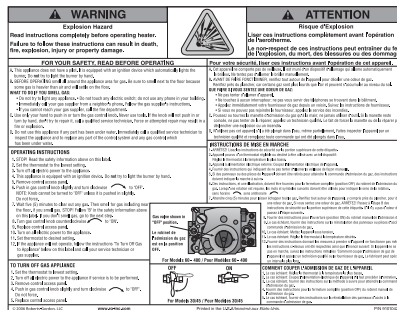
Manual Reset Switch Label



Rating Plate Label



Warning Label



Lighting Instructions Label

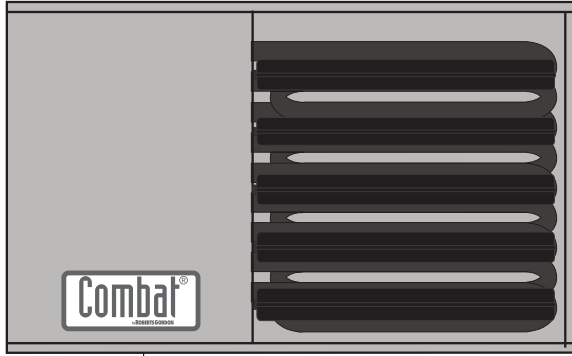
Description	Part Number
Logo Label	91040030
Cut Hazard Label	91010430
Vent Length Label	91039505
Vent to Outdoors Label	91010427
Warning Label	91010429
Rating Plate Label	91010420
Installation Label	91010431
Instruction Location Label	91010433
Lighting Instruction Label	91010425
Venting Arrangement Label*	91010426
Manual Reset Switch Label	91010428

\* For separated combustion units only



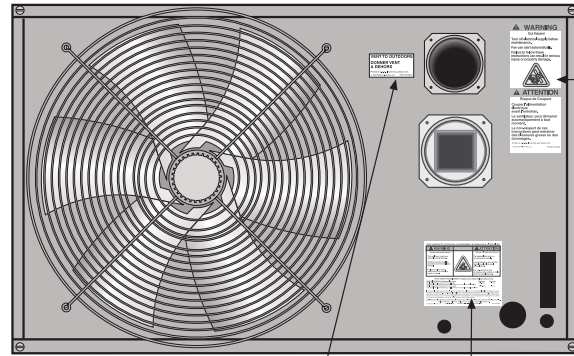
Figure 2: UHA 60 - 75 Label Placement

FRONT VIEW



Logo Label

BACK VIEW



**WARNING**  
Cut Hazard  
Turn off electrical supply before maintenance.  
Fan can start automatically. Failure to follow these instructions can result in serious injury or property damage.

**ATTENTION**  
Risque de Coupure  
Couper l'alimentation électrique avant l'entretien.  
Le ventilateur peut démarrer automatiquement à tout moment.  
Le non-respect de ces instructions peut entraîner des blessures graves ou des dommages.

Cut Hazard Label

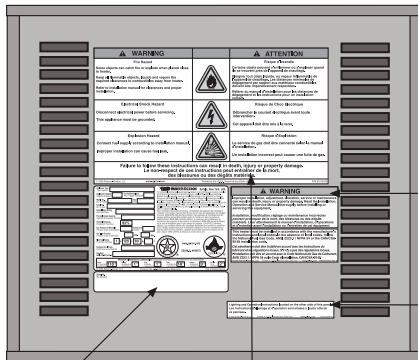
**VENT TO OUTDOORS**  
DONNER VENT  
À DEHORS  
Printed in U.S.A. / Imprimé aux États-Unis  
© 2006 Roberts-Gordon, LLC P/N 9104027

Vent to Outdoors Label

**VENT HEATER TO OUTDOORS / ÉCHAPPEMENT OU BRÛLEUR À L'EXTÉRIEUR**  
**WARNING**  
Ceux-ci doivent être installés dans un espace ventilé.  
Les unités doivent être installées dans un espace ventilé.  
Failure to follow these instructions can result in death, fire, explosion, injury or property damage.

Vent Length Label

ACCESS SIDE VIEW (OUTSIDE)



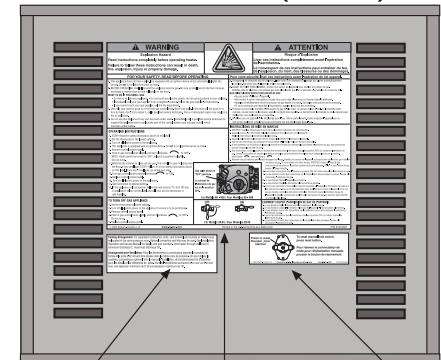
**WARNING**  
Improper installation, adjustment, alteration, service or maintenance can result in death, injury or property damage. Read the Installation, Operation and Service Manual thoroughly before installing or servicing this equipment.  
Installation, modification, réglage ou maintenance incorrectes peuvent provoquer de la mort, des blessures ou des dégâts matériels. Lire attentivement le manuel d'installation, d'opération et de maintenance avant l'installation ou l'entretien de cet équipement.  
This heater must be installed in accordance with the manufacturer's instructions and local codes. In the absence of local codes, follow the National Fuel Gas Code, ANSI Z223.1/NFPA 54 or the CAN/CSA-B149 installation code.  
Cet appareil doit être installé en accord avec les instructions de l'utilisateur et les réglementations locales. À l'absence de codes locaux, consultez le Code National du Gaz de Combustion, ANSI Z223.1/NFPA 54 ou le Code de l'Installation, CAN/CSA-B149.

Installation Label

Lighting and Operation Instructions located on the other side of this panel.  
Les instructions d'allumage et d'opération sont situées à l'autre côté de ce panneau.

Instruction Location Label

ACCESS SIDE VIEW (INSIDE)



**WARNING**  
Venting Arrangement: The approved venting system, with vent pipe and chimney, all listed and labeled in the case pressure case, should conform with listing in use. See Installation, Operation and Service Manual for details and instructions. Do not use any other venting system.  
Arrangement pour Ventilation: Pour les appareils à combustion rigides, le conduit de ventilation et le conduit de pression doivent être installés conformément aux spécifications de l'utilisateur, du fabricant et des codes locaux. Consultez le manuel d'installation, d'opération et de maintenance pour les détails et les instructions. Ne pas utiliser d'autres systèmes de ventilation.

\*Venting Arrangement Label

**ATTENTION**  
To reset manual limit switch, press reset button.  
Pour réinitialiser le limite pour réinitialisation manuelle, appuyez sur bouton de réinitialisation.

Manual Reset Switch Label

**WARNING**  
Fire Hazard  
Some objects can catch fire or explode when placed close to heater.  
Keep all flammable objects, liquids and vapors the required distance to combustibles away from heater.  
Read the installation manual for clearances and proper venting.  
Electrical Shock Hazard  
Disconnect electrical power before servicing.  
This appliance must be grounded.  
Explosion Hazard  
Connect fuel supply according to installation manual. Improper installation can cause fuel leaks.

Rating Plate Label

**WARNING**  
Fire Hazard  
Certains objets peuvent provoquer un incendie ou exploser quand ils sont placés près de l'appareil de chauffage.  
Éloignez les objets inflammables, les liquides et les vapeurs des combustibles à une distance requise.  
Lisez attentivement le manuel d'installation pour les distances de séparation et les instructions pour une installation appropriée.  
**ATTENTION**  
Risque d'Éclatement  
Débranchez le courant électrique avant toute intervention.  
Cet appareil doit être mis à la terre.  
Risque d'Explosion  
Le service de gaz doit être connecté selon le manuel d'installation.  
Une installation incorrecte peut causer une fuite de gaz.  
Failure to follow these instructions can result in death, injury or property damage.  
Le non-respect de ces instructions peut entraîner de la mort, des blessures ou des dégâts matériels.

Warning Label

**WARNING**  
Read instructions completely before operating heater. Failure to follow these instructions can result in death, fire, explosion, injury or property damage.  
**ATTENTION**  
Lire ces instructions complètement avant l'opération de l'appareil.  
Le non-respect de ces instructions peut entraîner des blessures graves ou des dommages.  
**FOR YOUR SAFETY, READ BEFORE OPERATING**  
1. Read the instructions carefully.  
2. Do not use the heater if you are unable to read these instructions.  
3. Do not use the heater if you are unable to understand the instructions.  
4. Do not use the heater if you are unable to understand the instructions.  
5. Do not use the heater if you are unable to understand the instructions.  
6. Do not use the heater if you are unable to understand the instructions.  
7. Do not use the heater if you are unable to understand the instructions.  
8. Do not use the heater if you are unable to understand the instructions.  
9. Do not use the heater if you are unable to understand the instructions.  
10. Do not use the heater if you are unable to understand the instructions.  
**PREVENT GAS LEAKAGE**  
1. Do not use the heater if you are unable to understand the instructions.  
2. Do not use the heater if you are unable to understand the instructions.  
3. Do not use the heater if you are unable to understand the instructions.  
4. Do not use the heater if you are unable to understand the instructions.  
5. Do not use the heater if you are unable to understand the instructions.  
6. Do not use the heater if you are unable to understand the instructions.  
7. Do not use the heater if you are unable to understand the instructions.  
8. Do not use the heater if you are unable to understand the instructions.  
9. Do not use the heater if you are unable to understand the instructions.  
10. Do not use the heater if you are unable to understand the instructions.

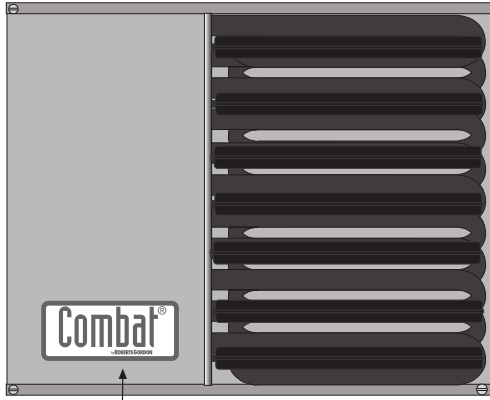
Lighting Instructions Label

Description	Part Number
Logo Label	91040030
Cut Hazard Label	91010430
Vent Length Label	91039505
Vent to Outdoors Label	91010427
Warning Label	91010429
Rating Plate Label	91010420
Installation Label	91010431
Instruction Location Label	91010433
Lighting Instruction Label	91010425
Venting Arrangement Label*	91010426
Manual Reset Switch Label	91010428

\* For separated combustion units only

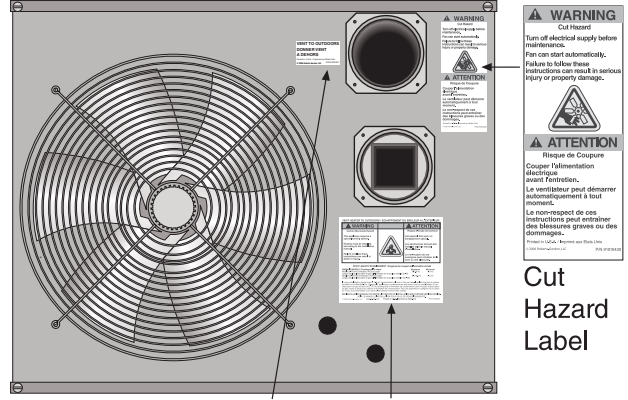
Figure 3: UHA 100 - 125 Label Placement

FRONT VIEW



Logo Label

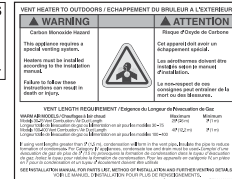
BACK VIEW



Cut Hazard Label

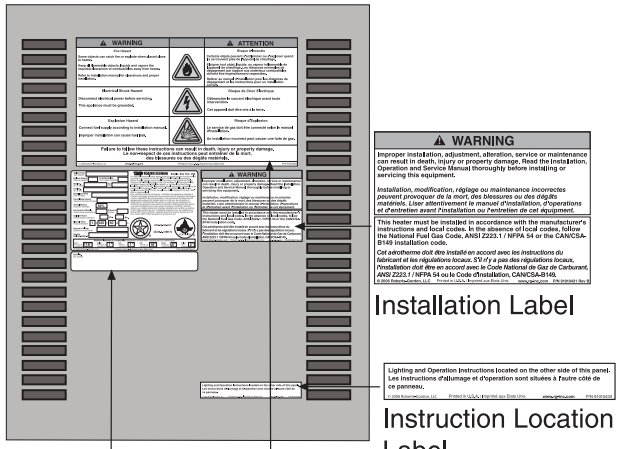


Vent to Outdoors Label



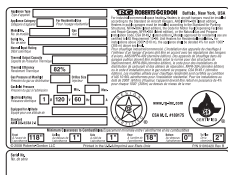
Vent Length Label

ACCESS SIDE VIEW (OUTSIDE)

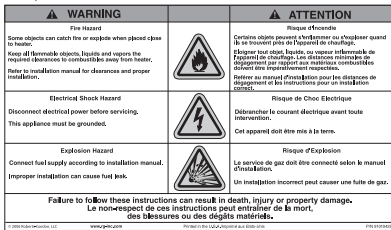


Installation Label

Instruction Location Label

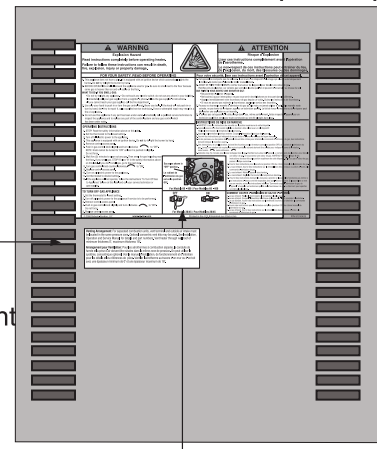


Rating Plate Label

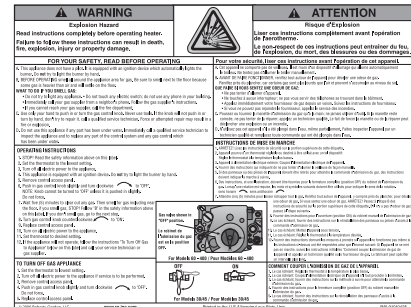


Warning Label

ACCESS SIDE VIEW (INSIDE)



\*Venting Arrangement Label



Lighting Instructions Label

Description	Part Number
Logo Label	91040030
Cut Hazard Label	91010430
Vent Length Label	91039505
Vent to Outdoors Label	91010427
Warning Label	91010429
Rating Plate Label	91010420
Installation Label	91010431
Instruction Location Label	91010433
Lighting Instruction Label	91010425
Venting Arrangement Label*	91010426

\* For separated combustion units only

## SECTION 2: INSTALLER RESPONSIBILITY

The installer is responsible for the following:

- To install the heater, as well as the gas and electrical supplies, in accordance with applicable specifications and codes. Roberts-Gordon recommends the installer contact a Local Building Inspector or Fire Marshal for guidance.
- To use the information given in a layout drawing and in the manual together with the cited codes and regulations to perform the installation.
- To install the heater in accordance with the clearances to combustibles.
- To furnish all needed materials not furnished as standard equipment.
- To plan location of supports, vents and air intakes.
- To provide access for servicing.
- To provide the owner with a copy of this Installation, Operation and Service Manual.
- To never use heater as support for a ladder or other access equipment and never hang or suspend anything from heater.
- To ensure there is adequate air circulation around the heater and to supply air for combustion, ventilation and distribution in accordance with local codes.

### 2.1 Wall Tag

A laminated wall tag is included with the heater as a permanent reminder of the safety instructions and the importance of the required clearances to combustibles. Affix the tag by peeling off the backing of the adhesive strips on the rear surface and position the tag on a wall near the heater.

A copy of the wall tag (P/N 91040031) is illustrated on the back cover.

Know your model number. Model number is found on the heater and throughout the Installation, Operation and Service Manual.

### 2.2 Corrosive Chemicals

**Caution:** Do not use heater in an area containing corrosive chemicals. Avoid the use of corrosive chemicals to ensure a longer life of the burner, heat exchanger and other parts.

Roberts-Gordon cannot be responsible for ensuring that all appropriate safety measures are undertaken prior to installation; this is entirely the responsibility of the installer. It is essential that the contractor, the sub-contractor, or the owner identifies the presence

of combustible materials, corrosive chemicals or halogenated hydrocarbons\* anywhere in the premises.

*\* **Halogenated Hydrocarbons** are a family of chemical compounds characterized by the presence of halogen elements (fluorine, chlorine, bromine, etc.). These compounds are frequently used in refrigerants, cleaning agents, solvents, etc. If these compounds enter the air supply of the burner, the life span of the heater components will be greatly reduced. An outside air supply must be provided to the burners whenever the presence of these compounds is suspected. Warranty will be invalid if the heater is exposed to halogenated hydrocarbons.*

### 2.3 National Standards and Applicable Codes

All appliances must be installed in accordance with the latest revision of the applicable standards and national codes. This refers also to the electric, gas and venting installation. Note: Additional standards for installations in public garages, aircraft hangars, etc. may be applicable.

### SECTION 3: CRITICAL CONSIDERATIONS

#### 3.1 Basic Information

UHA[X][S] heaters have automatic ignition burners for ON/OFF operation only.

#### 3.2 Manufactured Units

Gas-fired, power-vented unit heater with tubular heat exchanger. Units shall have a minimum of 82% thermal efficiency. The standard unit shall consist of a non-separated combustion design with an aluminized heat exchanger. Design and heat exchanger alternatives shall be offered as follows:

- **Separated Combustion:** A separated combustion unit shall consist of an enclosed sealed burner box to which combustion air is vented through a piece of internal flexible air duct. This duct terminates at an exterior cabinet flange to which a vent ran to the outside of the heated space should be attached.
- **Stainless Steel Heat Exchanger:** A stainless steel heat exchanger unit shall consist of heat exchanger tubes, heat exchanger tube supports, heat exchanger tube plates and a vent box produced of 409 stainless steel.

#### 3.3 Location and Suspension

All models:

- Must be installed indoors.
- Must be installed in a level position with horizontal discharge.
- May be mounted on a shelf of non-combustible material using shelf mounting brackets. (See Page 11, Figure 6 and Page 12, Figure 7 for details.)
- May be suspended from above (See Page 11, Figure 5) or from wall brackets of sufficient strength to support the heater as listed in the Dimension Data Table on Page 49, Section 15.1. Drop rods must be a minimum of 3/8" diameter mild steel. Four suspension points (3/8" nuts) are located on top of the heater.
- Must be installed in a manner which allows access to all serviceable components. See Page 7, Figure 4 for details.

#### 3.4 Minimum Required Installation Clearances


Clearances around the heater and vent must be as indicated on Page 7, Figure 4; Page 17, Figure 9 through Page 20, Figure 14 to ensure access for servicing, and correct operation.

#### 3.5 Clearances to Combustibles

<b>⚠ WARNING</b>	
	
<b>Fire Hazard</b>	
<b>Some objects can catch fire or explode when placed close to heater.</b>	
<b>Keep all flammable objects, liquids and vapors the required clearances to combustibles away from heater.</b>	
<b>Failure to follow these instructions can result in death, injury or property damage.</b>	

Clearances must be as indicated on Page 7, Figure 4. If clearances to combustibles are not indicated, then installation clearances apply.


#### 3.6 Ventilation

<b>⚠ WARNING</b>	
	<b>Carbon Monoxide Hazard</b>
	<b>Heaters may be installed vented or unvented.</b>
	<b>Vented heaters must be vented outdoors.</b>
	<b>Unvented heaters must be installed in buildings with ventilation rates as per section 6.4.</b>
<b>Failure to follow these instructions can result in death or injury.</b>	

It is important to ensure that there is adequate air space around the heater to supply air for combustion, ventilation and distribution in accordance with local and national code on Page 14, Section 6.

### 3.7 Gas Supply

**⚠ WARNING**



**Fire Hazard**

Connect gas supply according to Figure 15.

Do not use gas supply pipe and electrical connections to support heater's weight.


Gas can leak if not installed properly.

Failure to follow these instructions can result in death, injury or property damage.

It is important that the gas supply pipe is sized correctly to provide the inlet pressure as stated on the heater data plate. The gas supply pipe and electrical connections must not support any of the heater's weight. See Page 22, Section 8

### 3.8 Electrical Supply

**⚠ WARNING**



**Electrical Shock Hazard**

Disconnect electrical and gas supply before servicing.

This appliance must be connected to a properly grounded electrical source.

Failure to follow these instructions can result in death or electrical shock.

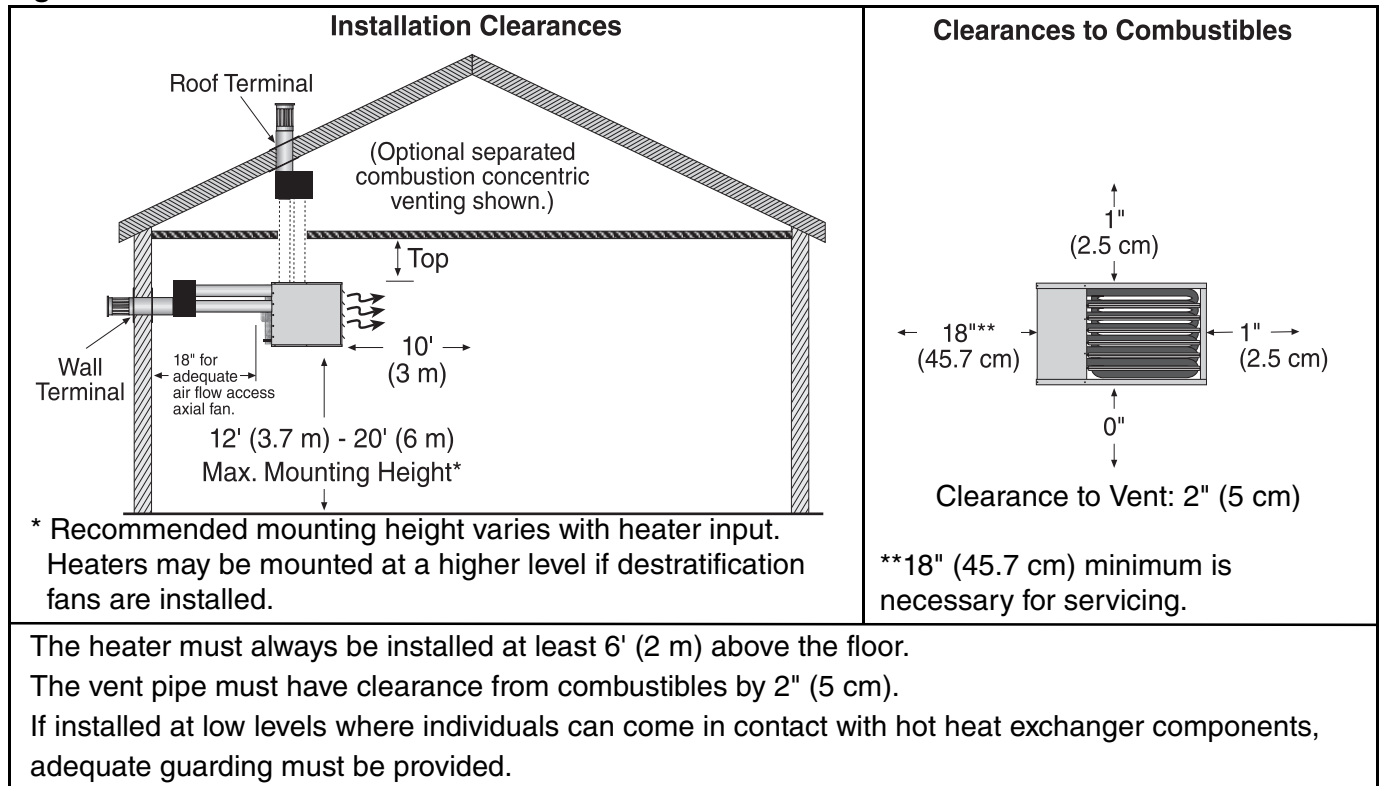
A permanent 120 V / 1 Ø / 60 Hz electrical supply is required for the main electrical power. The heater also requires suitable controls in accordance with See Page 23, Section 9.

### 3.9 Vent

Choose heater orientation to allow for the proper location of the vent. Each heater must be fitted with a correctly sized sealed vent system.

If vented horizontally, no other appliance may be connected to the vent. See Page 14, Section 6.

**Figure 4: Installation Clearances and Clearances to Combustibles**



**SECTION 4: NATIONAL STANDARDS AND APPLICABLE CODES**

**4.1 Gas Codes**

The type of gas appearing on the name plate must be the type of gas used. Installation must comply with national and local codes and requirements of the local gas company.

United States: Refer to NFPA 54/ ANSI Z223.1 - latest revision, National Fuel Gas Code.

Canada: Refer to CSA B149.1 Natural Gas and Propane Installation Code.

**4.2 Aircraft Hangars**

Installation in aircraft hangars must be in accordance with the following codes:

United States: Refer to Standard for Aircraft Hangars, NFPA 409 - latest revision.

Canada: Refer to Standard CSA B149.1 Natural Gas and Propane Installation Code.

- In aircraft storage and servicing areas, heaters shall be installed at least 10' (3 m) above the upper surface of wings or of engine enclosures of the highest aircraft which may be housed in the hangar. The measurement shall be made from the wing or engine enclosure (whichever is higher from the floor) to the bottom of the heater.
- In shops, offices and other sections of aircraft hangars communicating with aircraft storage or servicing areas, heaters shall be installed not less than 8' (2.4 m) above the floor.
- Suspended or elevated heaters shall be so located in all spaces of aircraft hangars that they shall not be subject to injury by aircraft, cranes, movable scaffolding or other objects. Provisions shall be made to assure accessibility to suspended heaters for recurrent maintenance purposes.

**4.3 Parking Structures and Repair Garages**

Installation in garages must be in accordance with the following codes:

United States: Standard for Parking Structures NFPA 88A - latest revision or the Code for Motor Fuel Dispensing Facilities and Repair Garages, NFPA 30A - latest revision. Canada: Refer to CSA B149.1 Natural Gas and Propane Installation Code.

- In accordance with the Standard for Parking Structures NFPA 88A, heaters must be located a minimum of 18" (50 cm) below the floor-ceiling assembly or 18" (50 cm) above the floor.
- In accordance with the Code for Motor Fuel Dispensing Facilities and Repair Garages, NFPA 30A - latest revision, heaters must not be installed less than 8' (2.4 m) above the floor.

**4.4 Electrical**

The heater must be electrically grounded in accordance with the following codes:

United States: Refer to National Electrical Code®, NFPA 70 - latest revision. Wiring must conform to the most current National Electrical Code®, local ordinances and any special diagrams furnished.

Canada: Refer to Canadian Electrical Code, CSA C22.1 Part 1 - latest revision.

**4.5 Venting**

The venting must be installed in accordance with the requirements within this manual and the following codes:

United States: Refer to NFPA 54/ANSI Z223.1 - latest revision, National Fuel Gas Code.

Canada: Refer to CSA B149.1 Natural Gas and Propane Installation Code.

**4.6 High Altitude**

These heaters are CSA-approved (without modifications) for installations up to 2000' (610 m) in US and Canada. CSA approved heaters installed above 2000' (610 m) must be de-rated. For installations above 2000' (610 m) in US, consult factory for information on burner de-rating. For installations from 2000' (610 m) to 4500' (1370m) in Canada, high altitude conversion kits are available. Heaters installed over 4500' (1370 m) in Canada are not CSA-approved and must be approved by the local or provincial authority.

**SECTION 5: MAJOR COMPONENTS**

**5.1 General**

Heaters are designed for installation above 6' (1.8 m). These heaters must be installed within the heated space. Duct delivery systems are not permitted with axial fan units. When handling or supporting the heater from below, ensure that the weight is taken at the support points.

The gas or electrical supply lines must not be used to support the heater.

Do not locate the gas or electrical supply lines directly over the path of the flue products from the heater.

The heater must be installed in accordance with clearances to combustibles as indicated on the wall tag and this manual.

**5.2 Shelf Mounting and Suspension**



Four suspension points (3/8" nuts) are located on the top of the heater. Drop rods must be 3/8" diameter mild steel.

When handling or supporting the heater from below, ensure that the weight is taken at the support points.

For typical suspension, See Page 11, Figure 5.

For typical shelf mounting on existing shelf, See Page 11, Figure 6

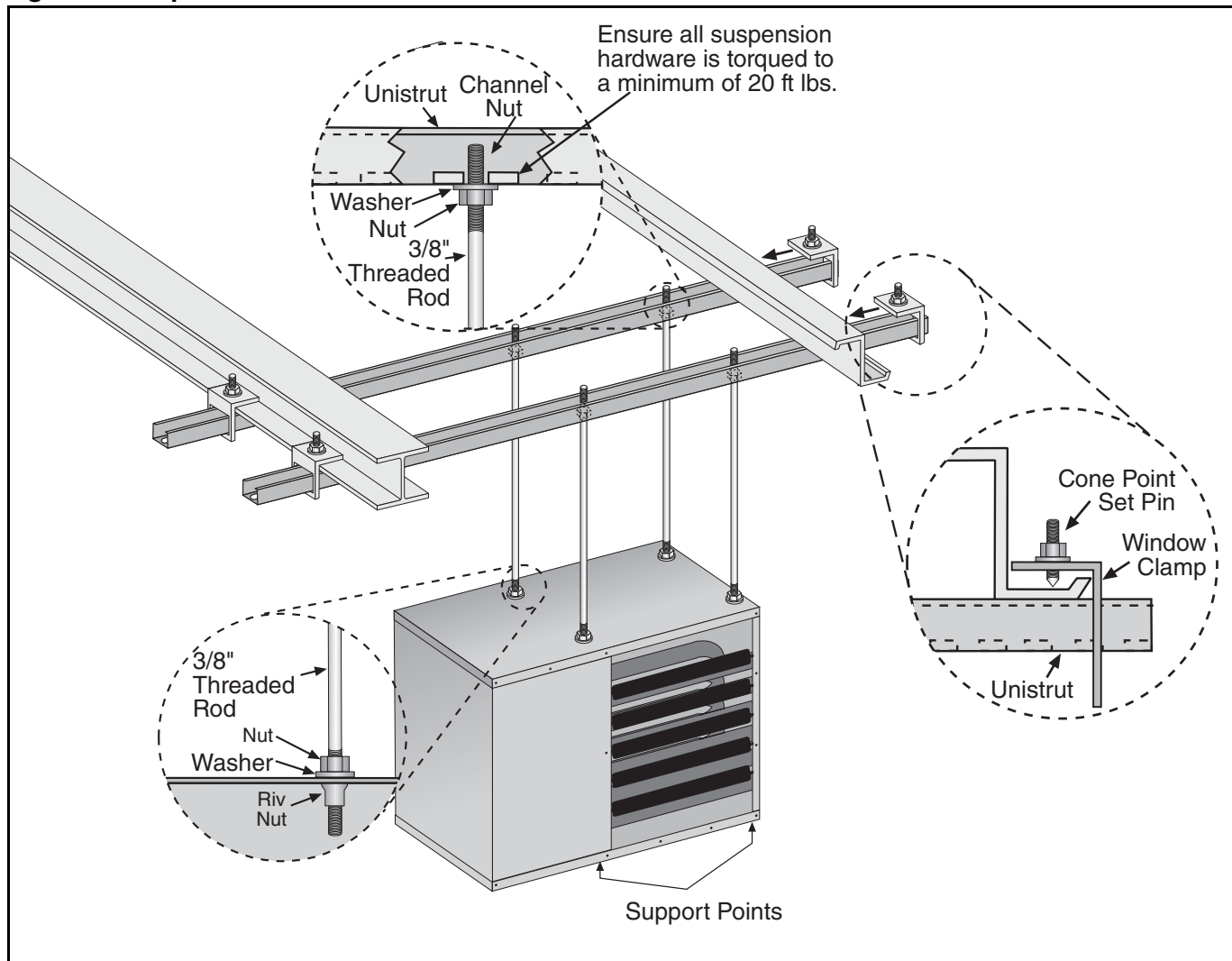
**5.3 Wall Mounting**

For typical suspension, See Page 12, Figure 7. Wall mounted heaters blowing parallel to the wall can only be installed with the service door away from the wall.

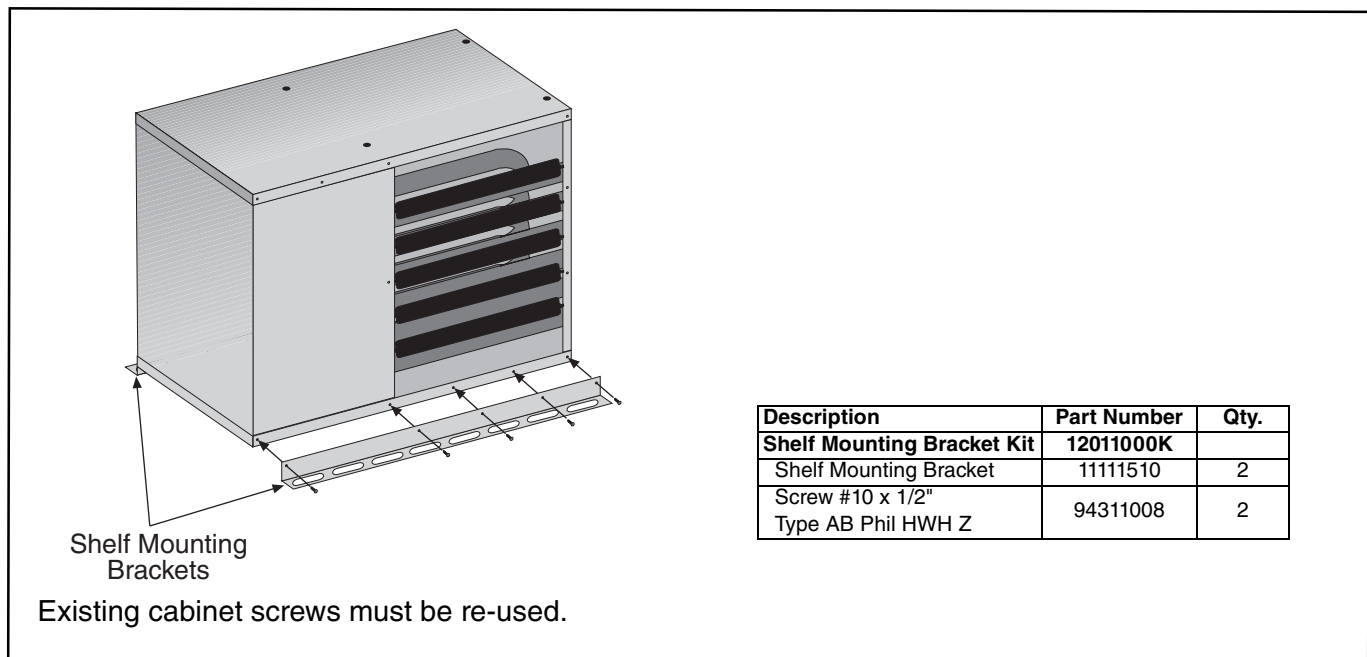
The wall mounting brackets must be attached to a suitable wall using all mounting holes. Screw sizes less than 3/8" may not be used. In order for the wall mounting brackets to adequately carry the weight of the heater, it must be installed according to best building practices.



**Figure 5: Suspension Methods**



**Figure 6: Shelf-Mounting Methods**



**Figure 7: Wall Shelf Mounting and Hanging Suspension**

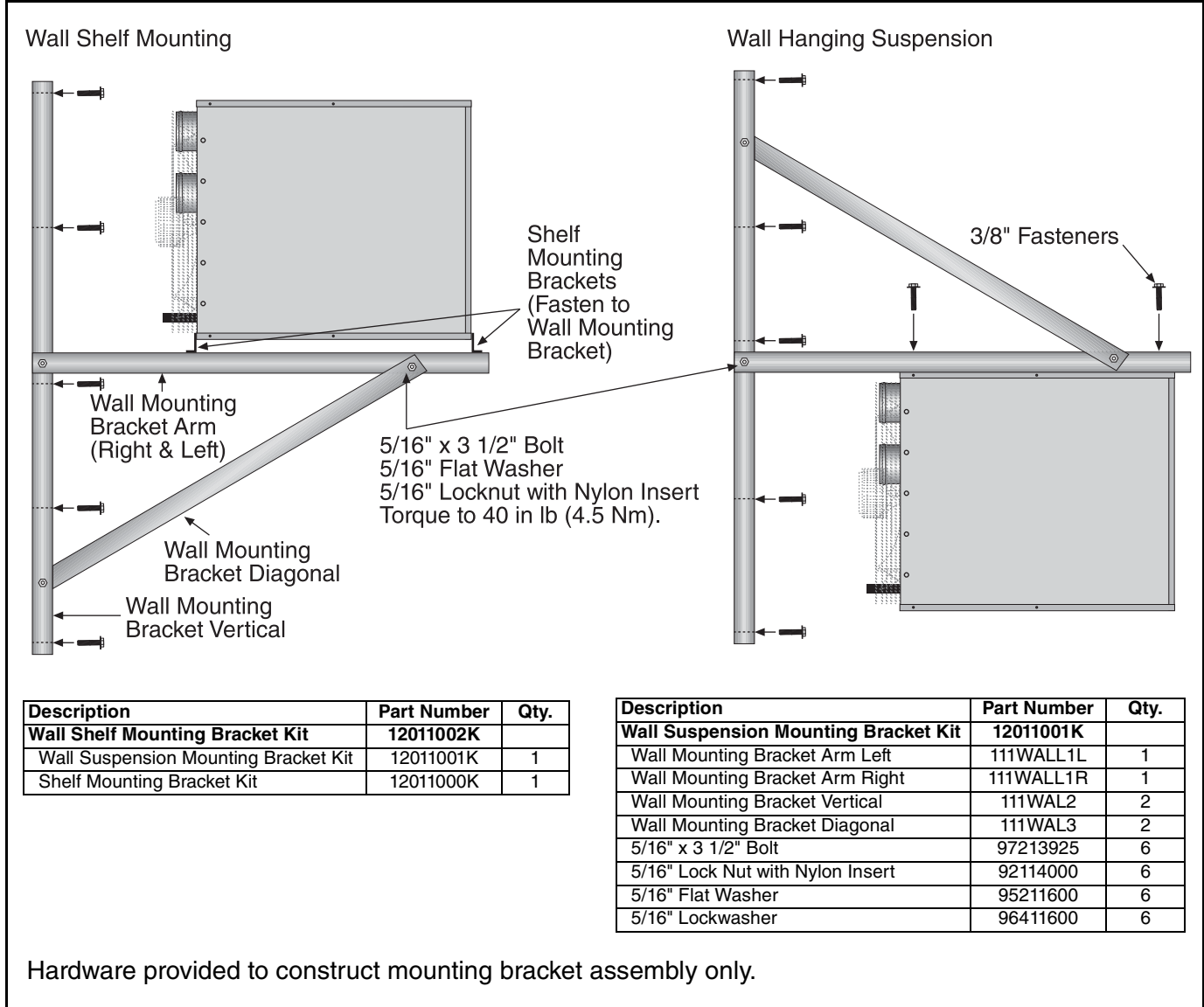
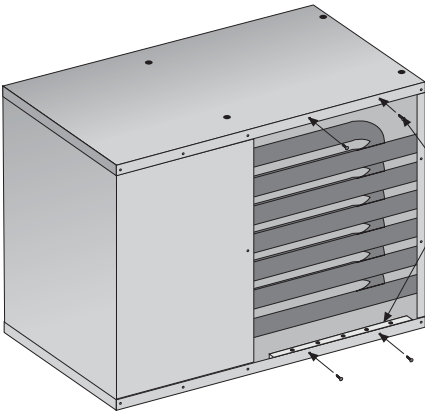
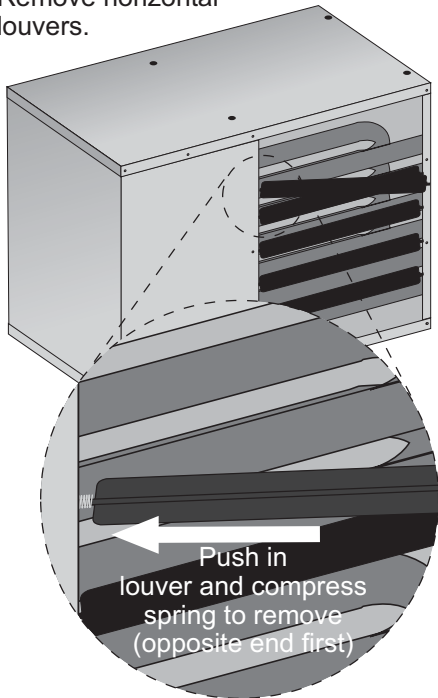
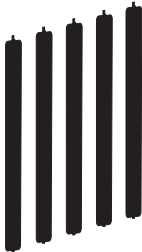


Figure 8: Vertical Louvers (Optional)

Remove horizontal louvers.



Install vertical louvers brackets (top and bottom) with supplied screws.



Install vertical louvers and springs into brackets with springs at top.


Description	Part Number	Qty.
<b>Vertical Louver Kit UHA[X][S] 30 &amp; UHA[X][S] 45</b>	<b>12011003K</b>	
Vertical Louver Bracket	11111903	2
#10 Screw	94311008	4
UHA[X][S] 30 - 45 Vertical Louvers	11111901	5
Louver Spring	90901200	2
Instruction Sheet	91040036	1

Description	Part Number	Qty.
<b>Vertical Louver Kit UHA[X][S] 60 &amp; UHA[X][S] 75</b>	<b>12011005K</b>	
Vertical Louver Bracket	11111903	2
#10 Screw	94311008	4
Instruction Sheet	91040036	1

Description	Part Number	Qty.
<b>Vertical Louver Kit UHA[X][S] 100 &amp; UHA[X][S] 125</b>	<b>12011004K</b>	
Vertical Louver Bracket	11111903	2
#10 Screw	94311008	4
UHA[X][S] 100 - 125 Vertical Louvers	11111902	5
Instruction Sheet	91040036	1

For models UHA[X][S] 60 and UHA[X][S] 75, horizontal louvers are re-used.

**SECTION 6: VENTING**

<b>⚠ WARNING</b>	
	<b>Carbon Monoxide Hazard</b>
	<b>Heaters may be installed vented or unvented.</b>
	<b>Vented heaters must be vented outdoors.</b>
	<b>Unvented heaters must be installed in buildings with ventilation rates as per section 6.4.</b>
<b>Failure to follow these instructions can result in death or injury.</b>	

**6.1 Changing Vent and Air Intake Orientation**

The heater is sold with rear horizontal vent and air intake connections as standard (only separated combustion models have air intake connection). If vertical vent and air intake connections are required, follow the instructions on *Page 46, Section 14.6*.

**6.2 Venting**

This heater must be vented in accordance with the rules contained in this manual and with the following national codes and any state, provincial or local codes which may apply: **United States:** Refer to NFPA54/ANSI Z223.1 - latest revision, National Fuel Gas Code; **Canada:** Refer to CSA B149.1 Natural Gas and Propane Installation Code.

Any portion of vent pipe passing through a combustible wall must have a listed thimble to conform with the above codes.

The heater may be installed unvented in certain circumstances according to building ventilation codes. Refer to the above codes and *Page 15, Section 6.4* for further information. Unvented operation also requires compliance with the clearances to combustibles given on *Page 7, Figure 4*.

The bottom of the vent or air intake terminal shall not be located less than 1' (.3 m) above grade level.

The vent shall not terminate less than 7' (2.1 m) above grade where located adjacent to public walkways.

Vent terminal must be installed at a height sufficient to prevent blockage by snow and building materials protected from degradation by flue gasses.

Vent terminal must be beyond any combustible overhang.

Secure all joints with corrosion resistant #8 x 3/8"

sheet metal screws.

For single wall venting, pressure sensitive aluminum tape or silicone sealant must be used to seal all joints.

Aluminum tape shall have a minimum temperature rating of 400° F (204° C) and meet SMACNA AFTS-100-73 standards. High temperature silicone sealant must have a minimum temperature rating of 480° F (250° C).

**6.2.1 United States Requirements**

Vent must terminate at least 3' (.9 m) above any forced air inlet located within 10' (3.1 m).

Vent must terminate at least 4' (1.2 m) below, 4' (1.2 m) horizontally from, or 1' (.3 m) above any door, operable window, or gravity air inlet into any building.

NFPA 54/ANSI Z223.1 - latest revision, National Fuel Gas Code specifies a 4' (1.2 m) horizontal vent terminal clearance from gas and electric meters, regulators and relief equipment.

**6.2.2 Canadian Requirements**

The vent shall not terminate within 6' (1.8 m) of a mechanical air supply inlet to any building.

The vent shall not terminate within 3' (.9 m) of a window or door that can be opened in any building, any non-mechanical air supply inlet to any building, or of the combustion air inlet of any other appliance.

**6.3 Vent Installation**

Maintain clearances to combustibles at all times for safety. Clearances are the required distances that combustible objects must be away from the heater to prevent serious fire hazard. See *Page 7, Figure 4*. For vented units, the vent must terminate outside of the building.

Vents must be fully sealed and correctly sized for the model. If the vent passes through a wall or ceiling of combustible material, it must be enclosed by a listed thimble and be separated from the thimble by at least a 2" (5 cm) air gap.

For separated combustion models, vents and air intakes must be a fully sealed system and correctly sized for the model. Vent should be assembled as detailed on *Page 17, Figure 9 through Page 20, Figure 14*. The joints between the vent terminal and the roof or wall must be properly sealed. If the vent passes through a wall or ceiling of combustible material, it must be enclosed by a listed thimble and be separated from the thimble by at least a 2" (5 cm) air gap.

**Vents and air intakes must be adequately supported so that the heater does not bear the weight of the pipes.**

For vent termination See Page 17, Figure 9 through Page 20, Figure 14.

**6.3.1 Standard Vented Heaters  
(Models UHA[X] 30 - 125)**

The vent must be fitted with a low resistance terminal. See Page 17, Figure 9 through Page 17, Figure 10. Standard vented heaters do not allow outdoor air intake for combustion air.


**6.3.2 Separated Combustion Heaters  
(Models UHA[X]S 30 - 125)**

The heaters are designed to be installed as separated combustion heaters. The vent and air intake are run as separate pipes to the wall or roof terminals. See Page 19, Figure 12. As an option, the vent and air intake are run as separate pipes to a concentric vent box and a concentric vent/air intake pipe penetrates the wall or roof. See Page 19, Figure 13 and Page 20, Figure 14.

For separated combustion installation, the vent and air intake must be fitted with an individual and correctly sized sealed system and the vent and air intake must terminate at approved wall and roof terminals.

Separated combustion units may not be common vented. See Page 14, Section 6

**6.4 Unvented Operation**

<b>⚠ WARNING</b>	
	<b>Carbon Monoxide Hazard</b>
	<b>Heaters may be installed vented or unvented.</b>
	<b>Vented heaters must be vented outdoors.</b>
	<b>Unvented heaters must be installed in buildings with ventilation rates as per section 6.4.</b>
<b>Failure to follow these instructions can result in death or injury.</b>	

The heater must be vented when installed in residential buildings.

For unvented operation in commercial installations, sufficient ventilation must be provided in the amount of 4 cfm per 1000 Btu/h firing rate (United States); 3

cfm per 1000 Btu/h firing rate (Canada).

**WARNING:** Combustion by-products contain a chemical known to the State of California to cause cancer and birth defects or other reproductive harm.

**6.5 Horizontal Venting**

Horizontally vented heaters must be individually vented.

Vent pipe must be sloped ¼" (.6 cm) for every 1' (.3 m). For vent lengths greater than 5' (1.5 m), condensation will form. Insulation is recommended and condensation drains may be desired.

In noncombustible walls only, vent terminal (P/N 02537801-1P) may be used.

For 4" (10 cm) vents in either combustible or noncombustible walls, use vent terminal (P/N 90502100) or equivalent insulated vent terminal. Follow the manufacturer's instructions for proper installation.

Instead of an insulated vent terminal, a listed thimble (with 2" (5 cm) air gap) may be used with a 4" (10 cm) vent cap (P/N 90502102).

In the State of Massachusetts, the following regulations apply to horizontally-vented heaters certified for installation in structures used in whole or in part for residential purposes (UHA 30-75 only) and where the side wall exhaust vent termination is less than seven (7) feet above finished grade in the area of the venting, including but not limited to decks and porches:

Installation of Carbon Monoxide Detectors: At the time of installation of the side wall horizontal vented gas fueled equipment, the installing plumber or gasfitter shall observe that a hard wired carbon monoxide detector with an alarm and battery back-up is installed on the floor level where the gas equipment is to be installed. In addition, the installing plumber or gasfitter shall observe that a battery operated or hard wired carbon monoxide detector with an alarm is installed on each additional level of the dwelling, building or structure served by the side wall horizontal vented gas fueled equipment. It shall be the responsibility of the property owner to secure the services of qualified licensed professionals for the installation of hard wired carbon monoxide detectors

- In the event that the side wall horizontally vented gas fueled equipment is installed in a crawl space or an attic, the hard wired carbon monoxide detector with alarm and battery back-up may be installed on the next adjacent floor level.

- In the event that the requirements of this subdivision can not be met at the time of completion of installation, the owner shall have a period of thirty (30) days to comply with the above requirements; provided, however, that during said thirty (30) day period, a battery operated carbon monoxide detector with an alarm shall be installed.

Approved Carbon Monoxide Detectors: Each carbon monoxide detector as required in accordance with the above provisions shall comply with NFPA 720 and be ANSI/UL 2034 listed and IAS certified. Signage: A metal or plastic identification plate shall be permanently mounted to the exterior of the building at a minimum height of eight (8) feet above grade directly in line with the exhaust vent terminal for the horizontally vented gas fueled heating appliance or equipment. The sign shall read, in print size no less than one-half (1/2) inch in size, "GAS VENT DIRECTLY BELOW. KEEP CLEAR OF ALL OBSTRUCTIONS"

Inspection: The state or local gas inspector of the side wall horizontally vented gas fueled equipment shall not approve the installation unless, upon inspection, the inspector observes carbon monoxide detectors and signage installed in accordance with the provisions of 248 CMR 5.08(2)(a)1 through 4.

**6.6 Vertical Venting**

Vertically vented heaters can be common vented (up to four heaters). For vent lengths greater than 5' (1.5 m), condensation will form. Insulation is recommended and condensation drains may be desired. Venting through the top of the heater cabinet is not recommended if vent lengths are longer than 10' (3 m). In this case, vent from the rear of the heater cabinet then run the vent vertically and use a condensate drain at the bottom of the vertical vent. Vent pipe must be sloped 1/4" (.6 cm) for every 1' (.3 m).

For 4" (10 cm), an approved vent cap (P/N 90502102) must be used.

For 6" (15 cm) common vent, an approved vent cap (P/N 90502103) must be used.

For common vertical venting of more than two heaters, See Page 18, Figure 11.

A vent shall not extend less than 2' (.6m) above the highest point where it passes through a flat roof of a building.

**6.7 Length Requirements**

If using vent lengths greater than 5' (1.5 m), condensation will form in the vent pipe. Insulation and additional sealing measures (high temperature silicone at all seams) are required.

The entire vent should be insulated with foil faced fiberglass insulation (1/2" thick, 1-1/2# density minimum).

**6.7.1 Maximum Vent Lengths**

Model UHA[X][S] 30 - 60	Model UHA[X][S] 75 - 125	Number of Elbows
25 ft (7.6 m)	40 ft (12.2 m)	1
20 ft (6.1 m)	35 ft (10.7 m)	2
15 ft (4.6 m)	30 ft (9.1 m)	3
10 ft (3.0 m)	25 ft (7.6 m)	4
5 ft (1.5 m)	20 ft (6.1 m)	5

**6.8 Vent Material**

Vent material may be single wall 26 ga. (minimum) galvanized steel or equal thickness stainless steel. Completely seal all joints, refer to Page 14, Section 6.3.

If penetrating a combustible wall or roof, a listed thimble with 2" (5 cm) clearance must be used. Where local codes permit, a single section of type B-1 vent material may be used at the roof or wall penetration instead of a thimble. Ensure vent manufacturer's clearance from vent material is maintained. Seal annular space of the type B-1 vent as well as all joints in the remaining vent.

**6.9 Replacing an Existing Heater in a Venting System**

When replacing an existing heater in a venting system, the venting system may not be properly sized to vent the new heater. The following steps must be followed with each appliance connected to the venting system placed in operation, while any other appliances connected to the venting system are not in operation.

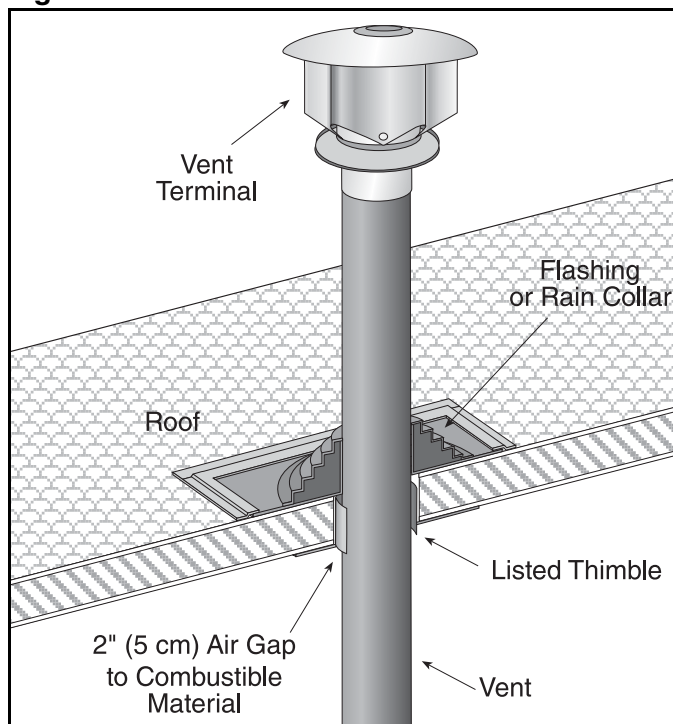
1. Seal any unused openings in the venting system.
2. Inspect the venting system for proper size and horizontal pitch, as required by the NFPA 54/ ANSI Z223.1 - latest revision, National Fuel Gas Code (US) or Standard CSA B149.1 Natural Gas and Propane Installation Code (Canada) and these instructions. Determine that there is no blockage or restriction, leakage, corrosion and other deficiencies which could cause an unsafe condition.
3. Close all building doors and windows and all doors between the space in which the appliance(s) connected to the venting system

are located and other spaces of the building. Turn on clothes dryers and any exhaust fans, such as range hoods and bathroom exhausts so that they shall operate at maximum speed. Do not operate a summer exhaust fan. Close fireplace dampers.

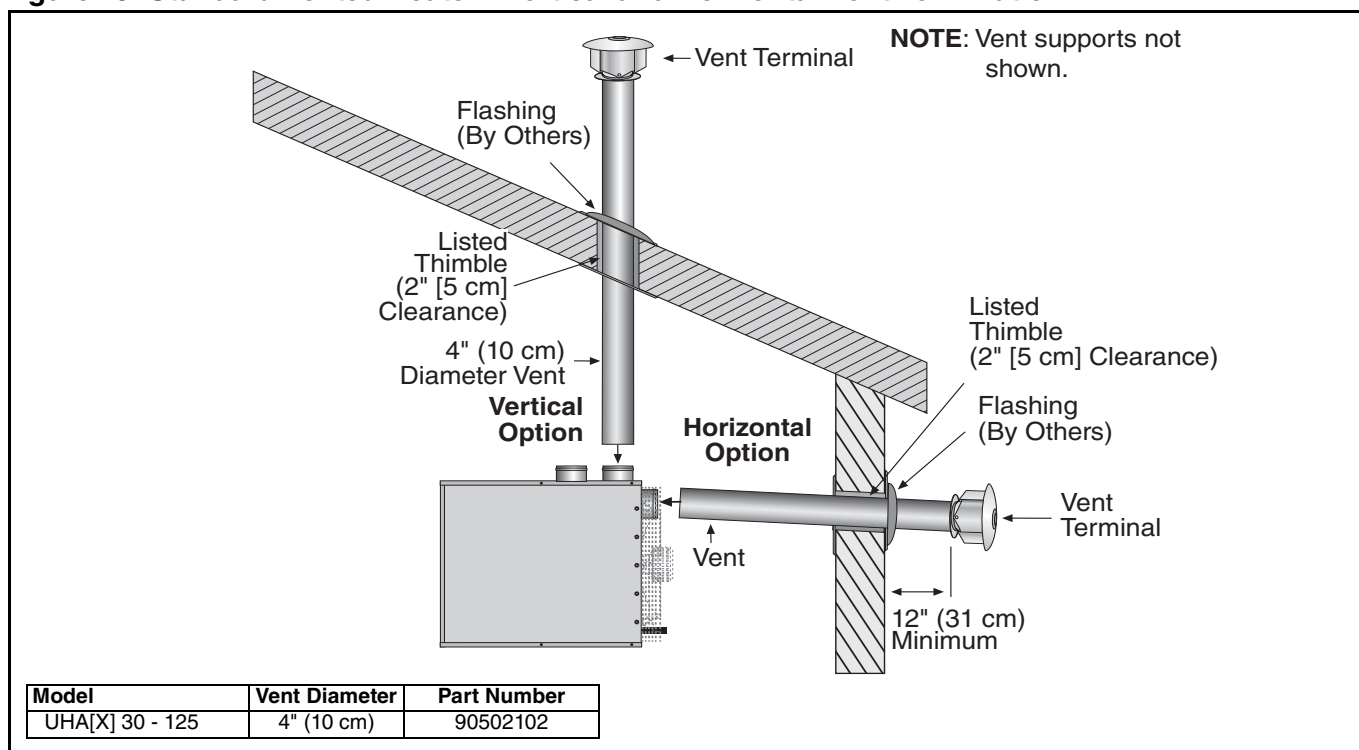
4. Follow the lighting instructions. Place the appliance being inspected in operation. Adjust thermostat so that the appliance will operate continuously.
5. For any appliance having a draft hood, test for draft hood appliance spillage at the draft hood relief opening after 5 minutes of main burner operation. Use the flame of a match or candle.
6. After it has been determined that each appliance connected to the venting system properly vents when tested as outlined above, return doors, windows, exhaust fans, fireplace dampers and any other gas-burning appliances to their previous conditions of use.
7. If improper venting is observed during any of the above tests, the venting system must be corrected by a contractor qualified in the installation and service of gas-fired equipment or your local gas supplier. If the venting must be resized, use appropriate tables in (US) Appendix G of NFPA 54/ANSI Z223.1 - latest revision, National Fuel Gas Code (US) or Standard CSA B149.1 Natural Gas and Propane Installation Code (Canada) to determine minimum size. All vent corrections

must be in accordance with the appropriate local codes and the NFPA 54/ANSI Z223.1 - latest revision, National Fuel Gas Code (US) or Standard CSA B149.1 Natural Gas and Propane Installation Code (Canada).

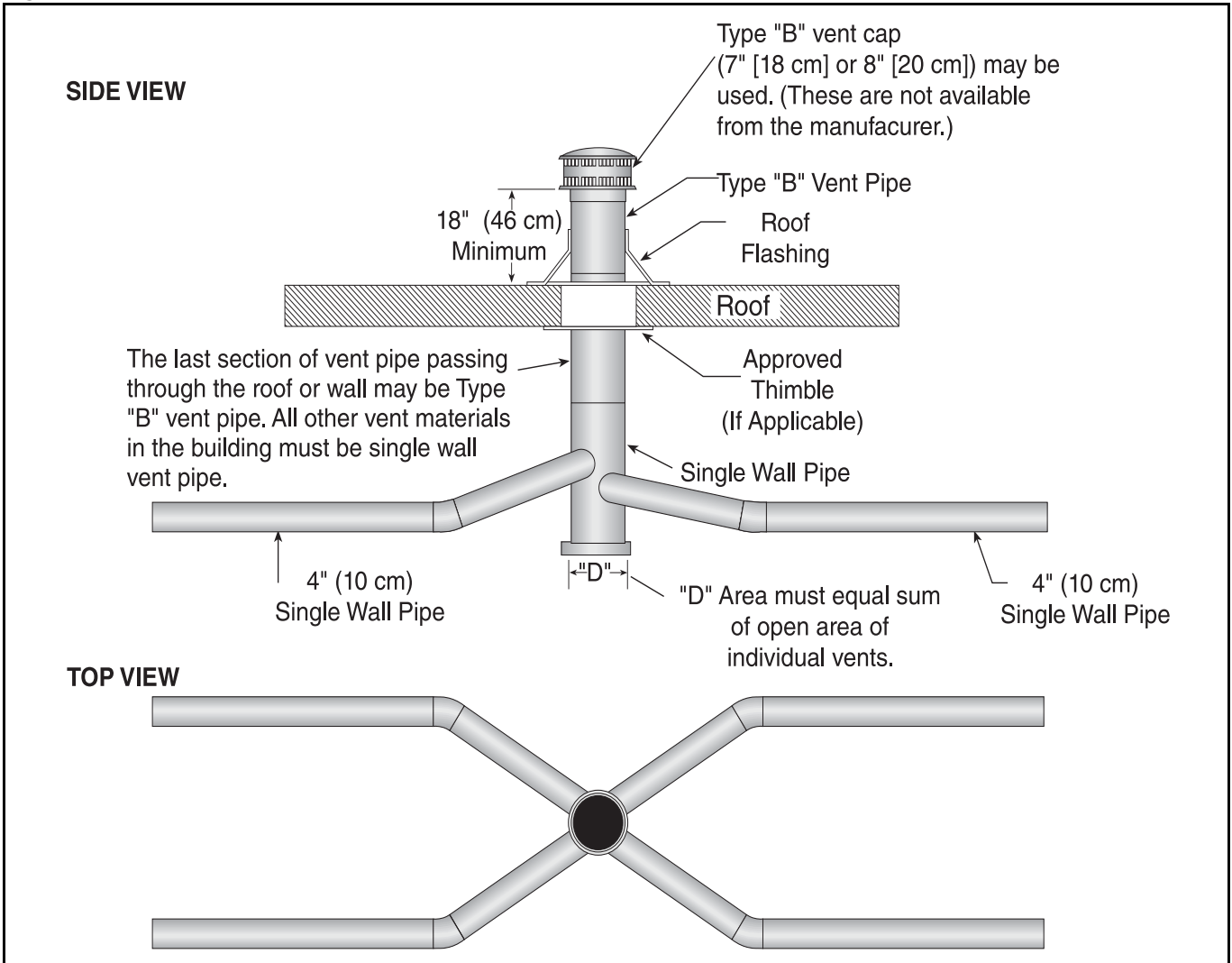
**Figure 9: Vent and Roof Detail**



**Figure 10: Standard Vented Heater - Vertical and Horizontal Vent Termination**

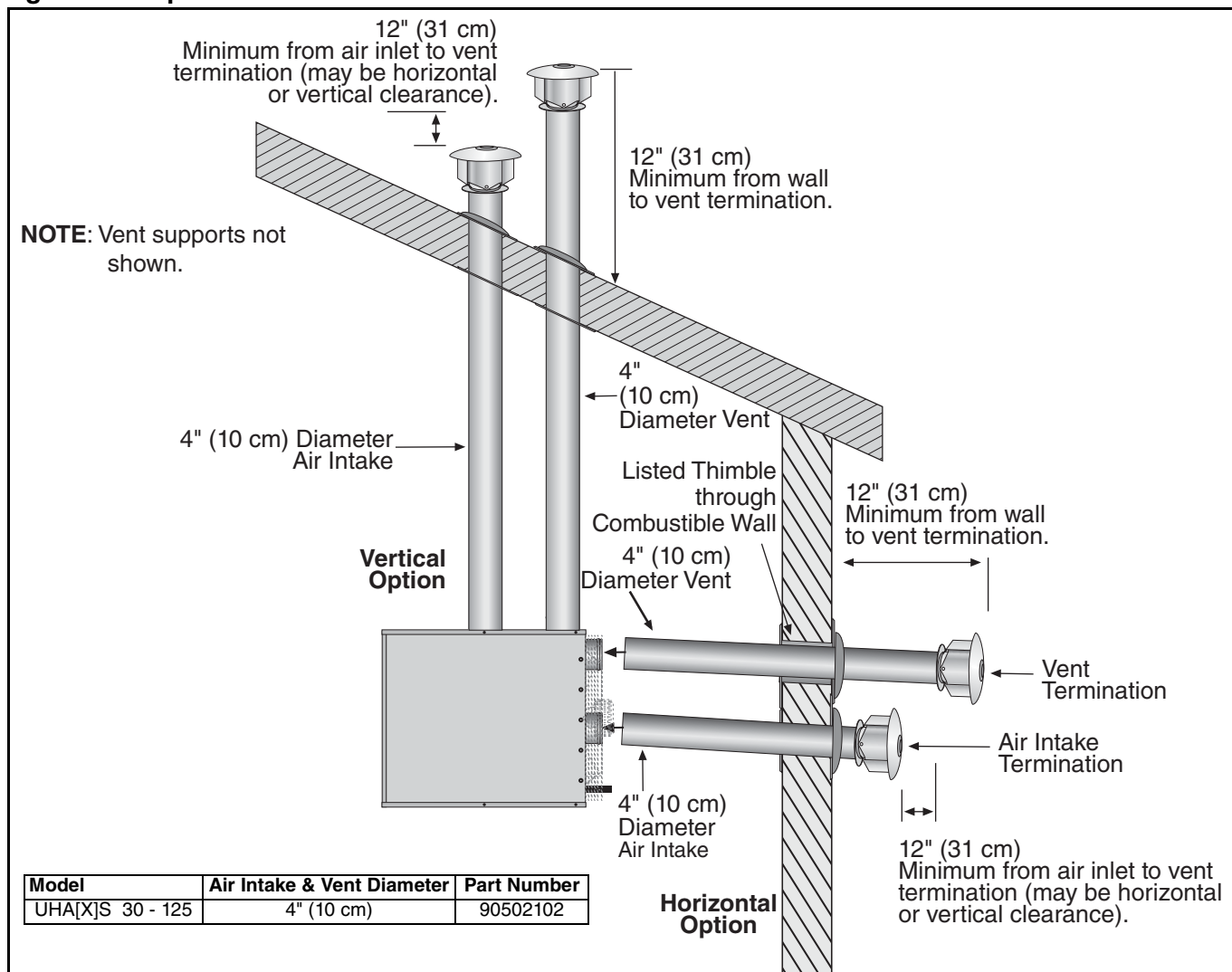


**Figure 11: Standard Vented Heater - Common Vertical Vent Termination**

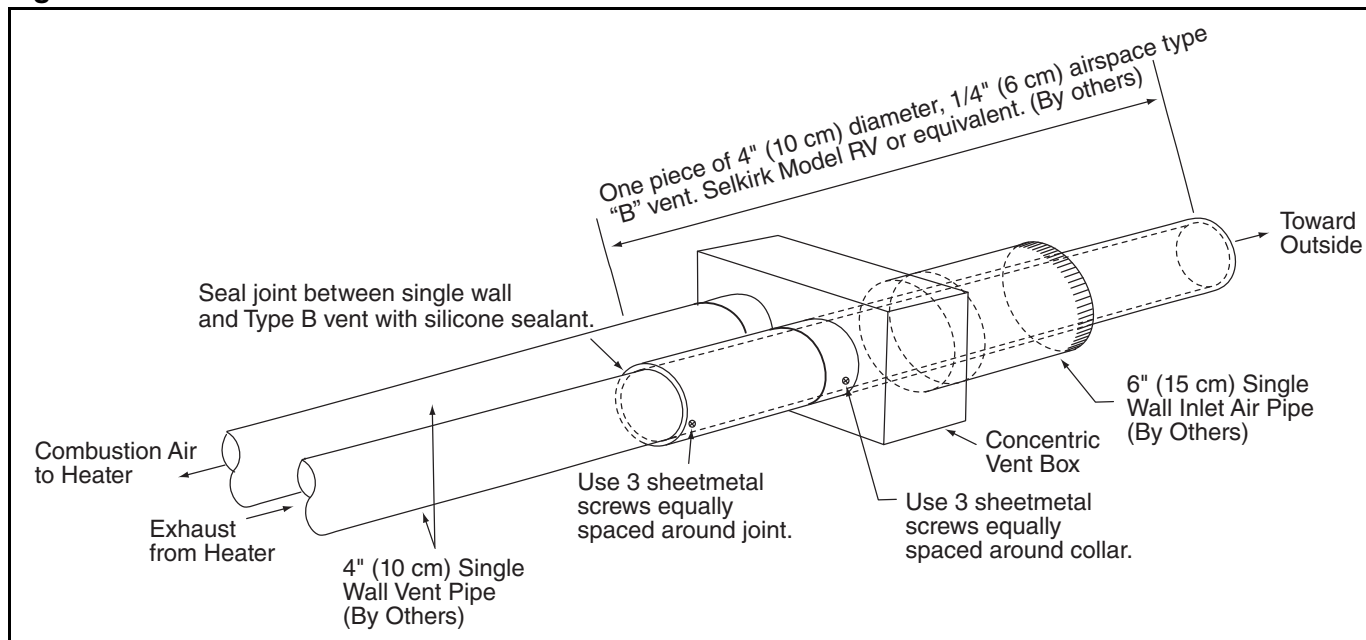




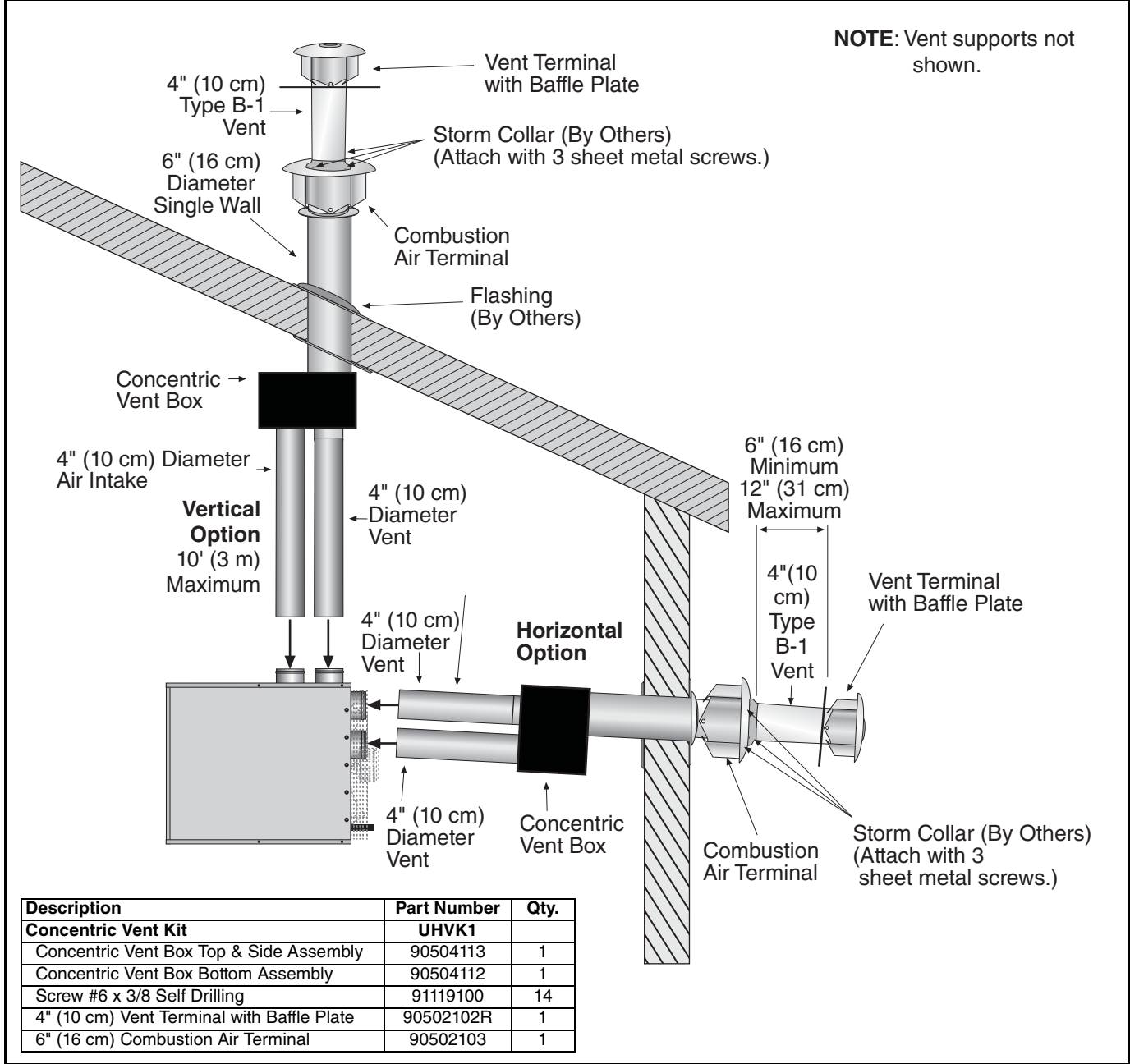
**Figure 12: Separated Combustion Heater - Vertical and Horizontal Vent Termination**



**Figure 13: Concentric Vent Box**



**Figure 14: Concentric Vertical and Horizontal Vent Termination - Separated Combustion Heater**



## SECTION 7: AIR SUPPLY

### 7.1 Separated Combustion Installation

When installed as a separated combustion heater (UHA[X]S), the air for combustion is drawn in from outside the building. It is important to ensure that there is adequate space around heater to provide air for the axial air distribution fan.

### 7.2 Unvented Installation

It is important to ensure that there is adequate fresh air supply at all times for both combustion and heating requirements in accordance with local and national codes.

**WARNING:** Combustion by-products contain a chemical known to the State of California to cause cancer and birth defects or other reproductive harm.

### 7.3 Building Ventilation

Where ventilation is required, air must be taken from an outside point where it is not likely to be contaminated or obstructed.

### 7.4 Outside Combustion Air Supply

If outside combustion air supply is required, separated combustion model (UHA[X]S) heaters must be used.


**Caution:** If the building has a slight negative pressure or corrosive contaminants such as halogenated hydrocarbons are present in the air, an outside combustion air supply to the heater is required. Seal all combustion air pipe joints. The flexible air duct may have to be insulated to prevent condensation on the outer surface. The outside air terminal must not be more than 1' (31 cm) above the vent terminal.

#### 7.4.1 Length Requirements

Follow the constraints listed on *Page 16, Section 6.7*.

**SECTION 8: GAS PIPING**

⚠ **WARNING**



**Fire Hazard**

**Connect gas supply according to Figure 15.**

**Do not use gas supply pipe and electrical connections to support heater's weight.**

**Gas can leak if not installed properly.**

**Failure to follow these instructions can result in death, injury or property damage.**

A gas meter is connected to the service pipe by the gas supply company. An existing meter should be checked, preferably by the company, to ensure that the meter is adequate for the rate of gas supply required.

Installation pipes must be fitted in accordance with local and national codes. Pipes of smaller size than the heater inlet gas connection should not be used.

**8.1 Connections**

Connect the heater to the gas supply ensuring that the final connections are as follows:

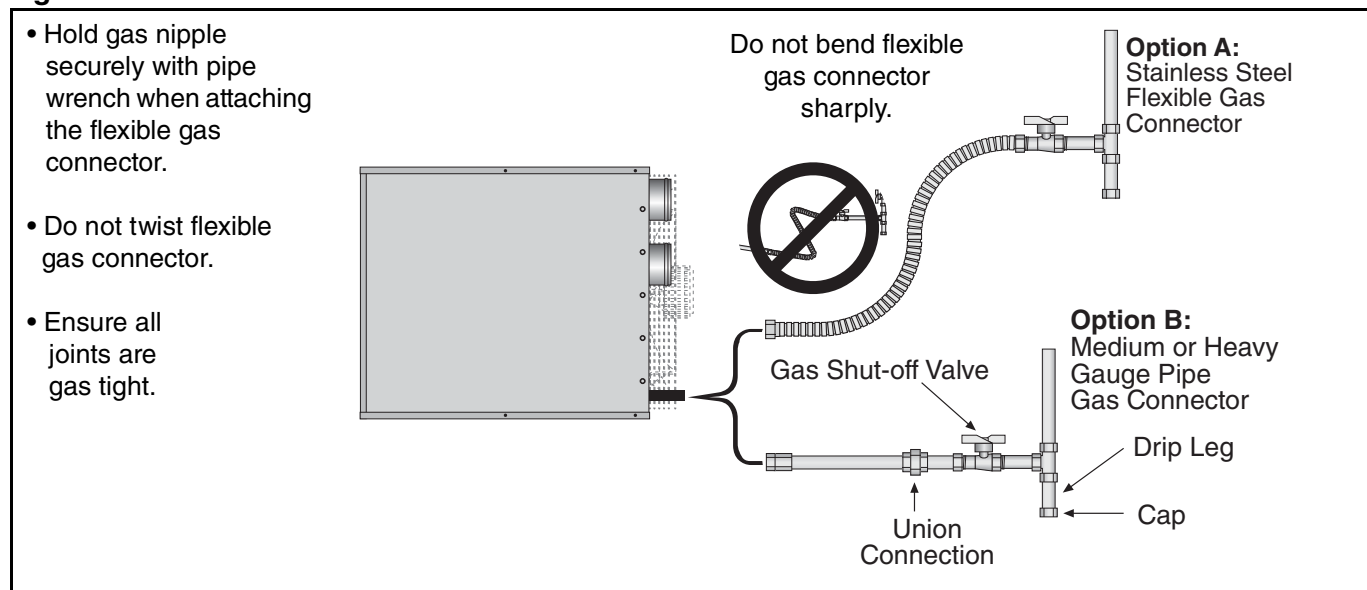
- Gas supply pipe work is run in medium or heavy gauge tubing in compliance with local and national codes.
- Meter and service must be large enough to handle all the burners being installed plus any other connected load. The gas pipe which feeds the system must be large enough to supply the required gas with a maximum pressure drop of 1/2" wc. When gas piping is not included in the layout drawing, contact the local gas supplier.
- An isolating valve and union connection should be used and fitted into the supply adjacent to the heater.
- A minimum 1/8" NPT plugged tapping accessible for test connection must be installed immediately upstream of the gas supply connection to the heater.
- For suspended heaters, an approved metal flexible connection between the isolating valve and the heater may be used. **To reduce pressure loss, use one pipe size larger than the heater gas connection.**

**IMPORTANT** - The complete installation must be purged and tested for gas soundness in accordance with local and national codes.

**Caution:** Do not high pressure (in excess of 1/2 psi [14" wc]) test the gas piping with the burner connected. Close manual shut-off valve during any pressure testing equal to or less than 1/2 psi (14" wc).

**Check the pipe and tubing ends for leaks before placing heating equipment into service. When checking for gas leaks, use a soap and water solution; never use an open flame.**

**Figure 15: Gas Connection**



## SECTION 9: WIRING

**⚠ WARNING****Electrical Shock Hazard**

**Disconnect electrical and gas supply before servicing.**

**This appliance must be connected to a properly grounded electrical source.**

**Failure to follow these instructions can result in death or electrical shock.**

All heater models require constant 120 V/1Ø/ 60 Hz power supply. Check heater rating plate for electrical rating for proper circuit sizing. For servicing, a disconnect switch of proper electrical rating should be installed in the vicinity of the heater. All heaters are equipped with thermostat connections suitable to power a 24 V thermostat. Heater must be wired and electrically grounded in accordance with local codes. In the absence of local

codes in accordance with: United States: refer to National Electrical Code® NFPA 70 - latest revision; Canada: refer to Canadian Electrical Code CSA C22.1 Part I - latest revision.

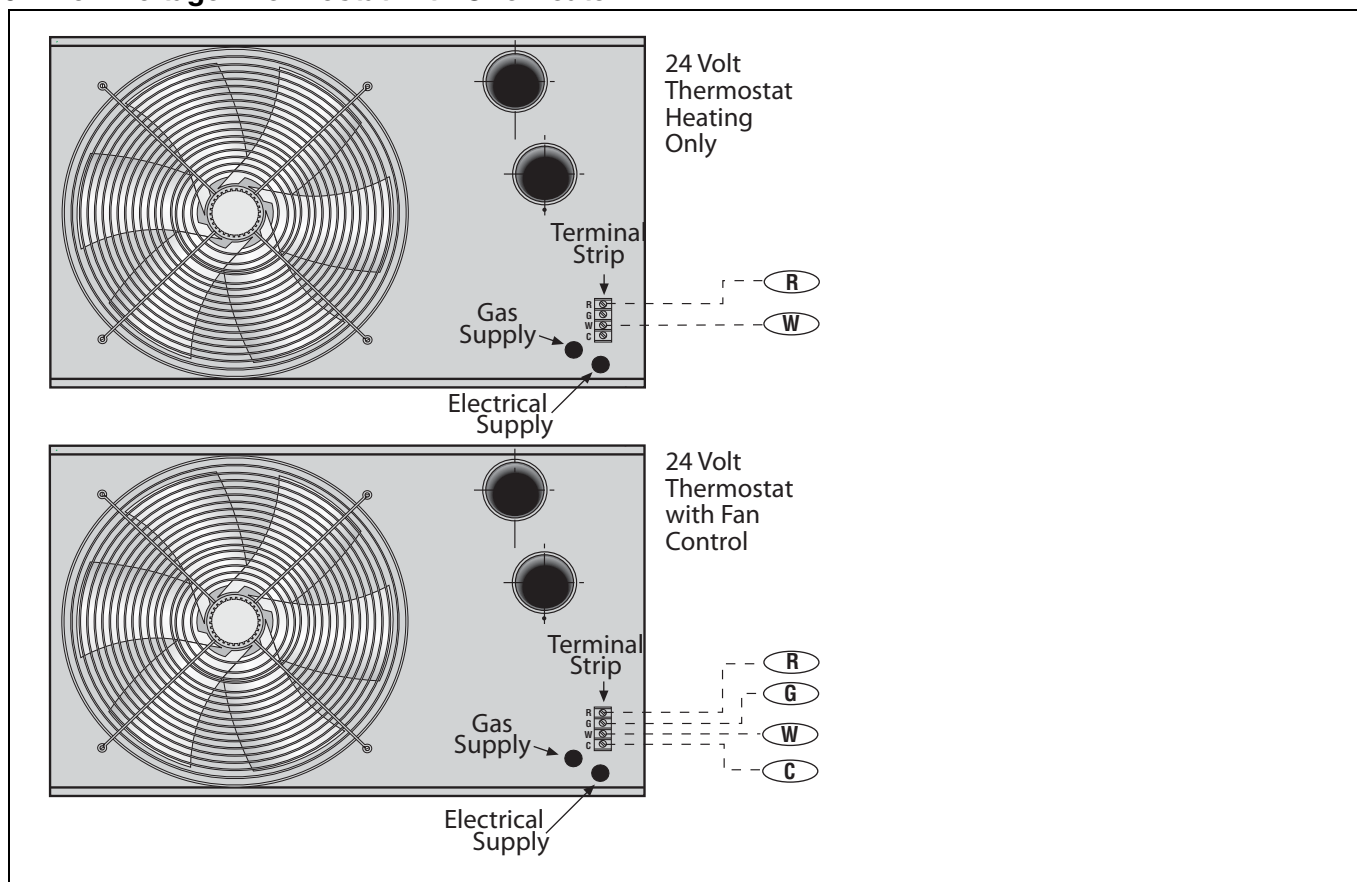
**9.1 Positioning Thermostats**

A room thermostat should be mounted on a vibration-free wall or column at a height of approximately 5' (1.5 m) from the floor to measure the ambient temperature. It should be clear of both cold drafts and the direct path of warm air from the heater.

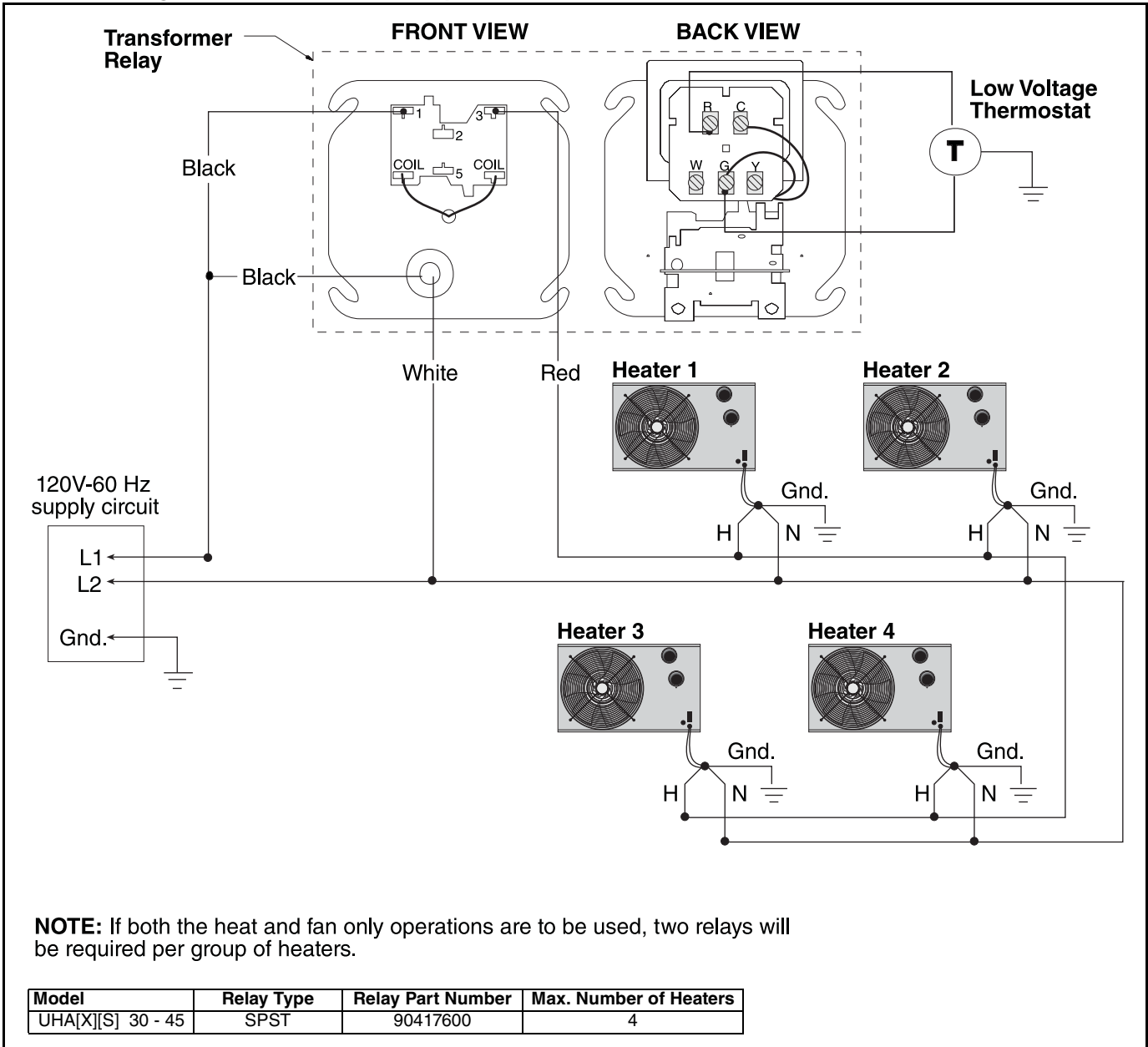
Avoid mounting thermostat on outside walls or in areas directly exposed to radiant heat or sunlight. Install wall tag in a visible location near thermostat. See Page 5, Section 2.1 for wall tag details.

**9.1.1 Fan Control**

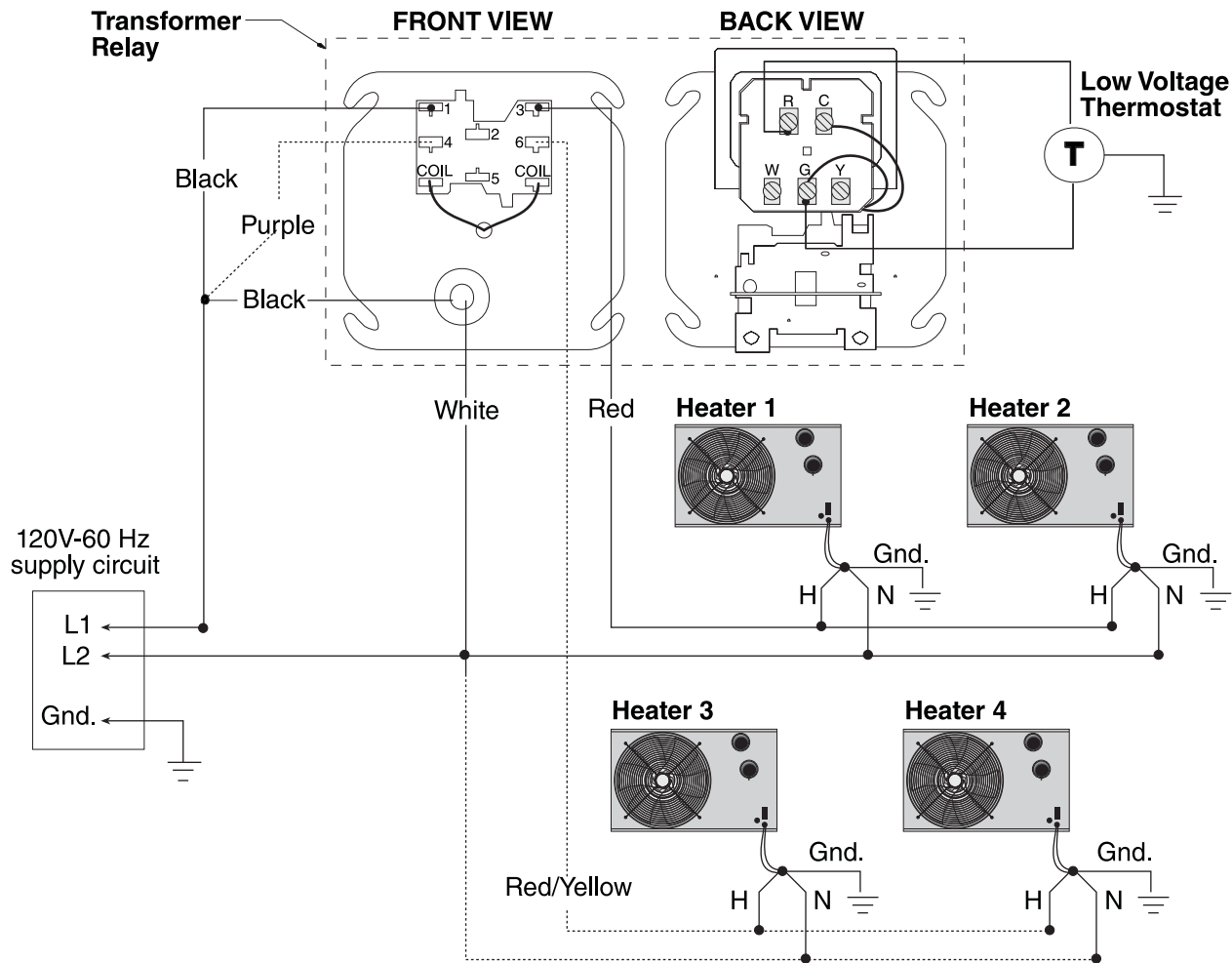
The heater's axial fan can be used during the off-season for air circulation. A low-voltage programmable thermostat with a fan switch (P/N 90425400) must be used. For thermostat connection details. For the use of multiple heaters on one thermostat, See Page 24, Section 9.3 through Page 25, Section 9.4

**9.2 Low Voltage Thermostat with One Heater**

9.3 Low Voltage Thermostat with Multiple Heaters 30 - 45



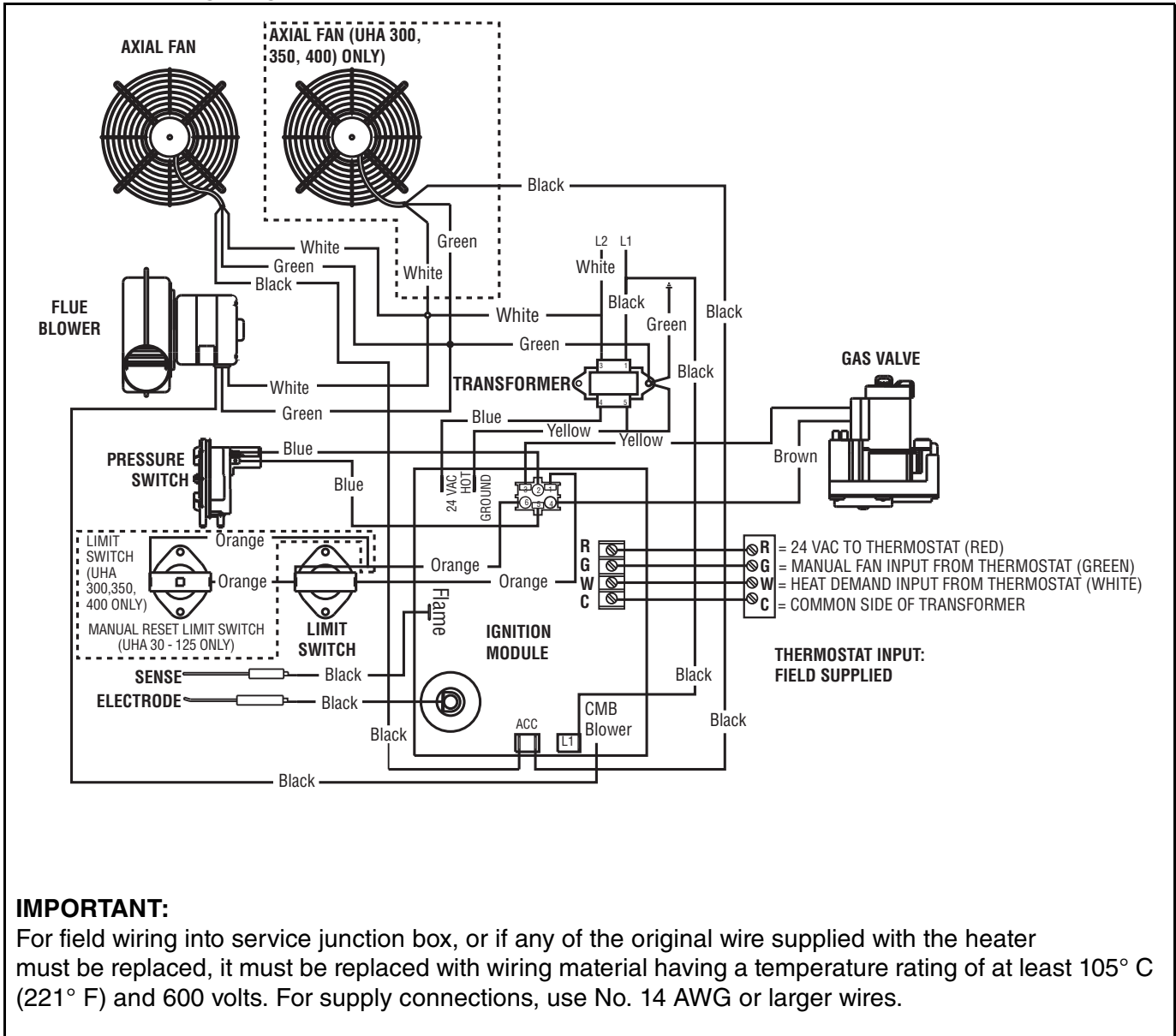
9.4 Low Voltage Thermostat with Multiple Heaters 60 - 125



**NOTE:** If both the heat and fan only operations are to be used, two relays will be required per group of heaters.

Model	Relay Type	Relay Part Number	Max. Number of Heaters
UHA[X][S] 60 - 125	DPST	90436300	4

### 9.5 Internal Wiring Diagram

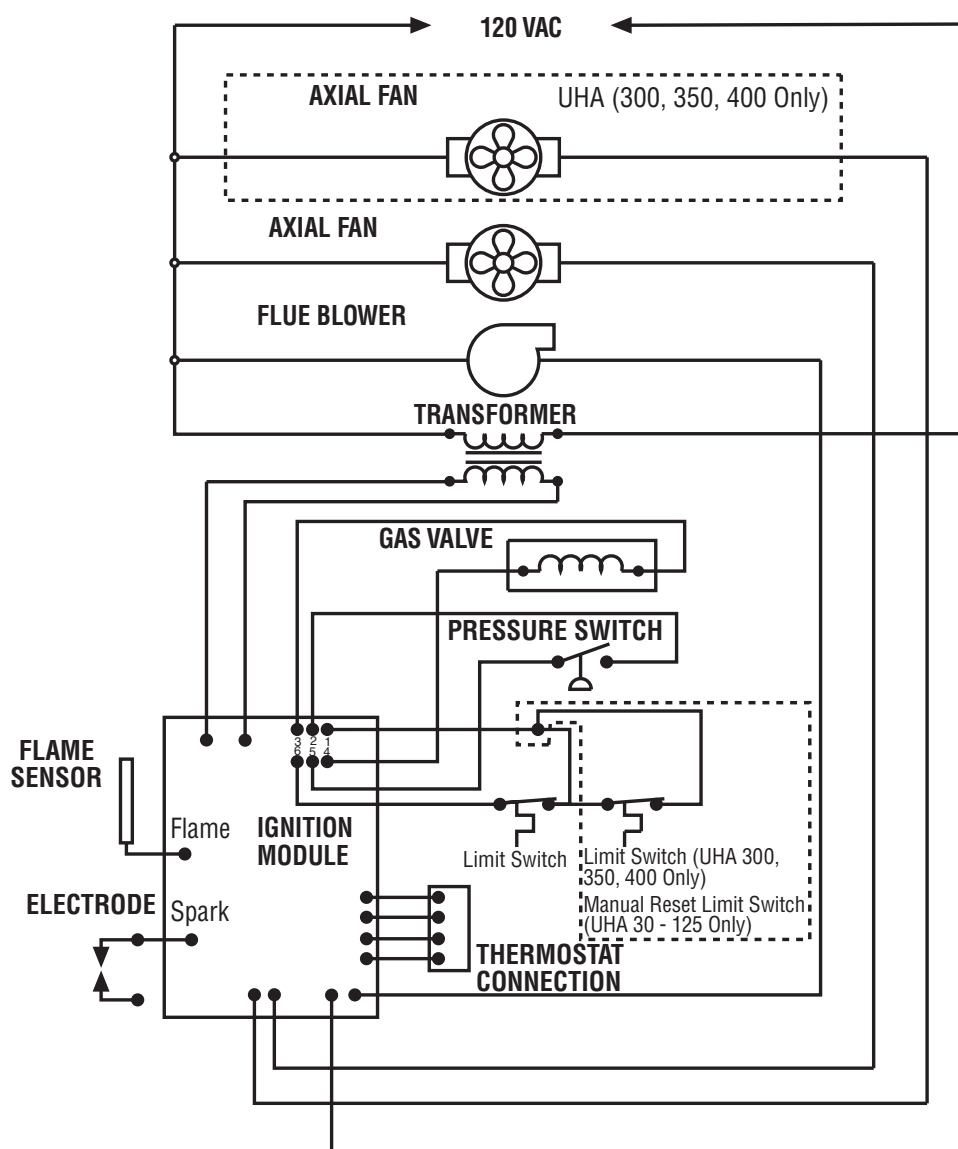


**IMPORTANT:**

For field wiring into service junction box, or if any of the original wire supplied with the heater must be replaced, it must be replaced with wiring material having a temperature rating of at least 105° C (221° F) and 600 volts. For supply connections, use No. 14 AWG or larger wires.

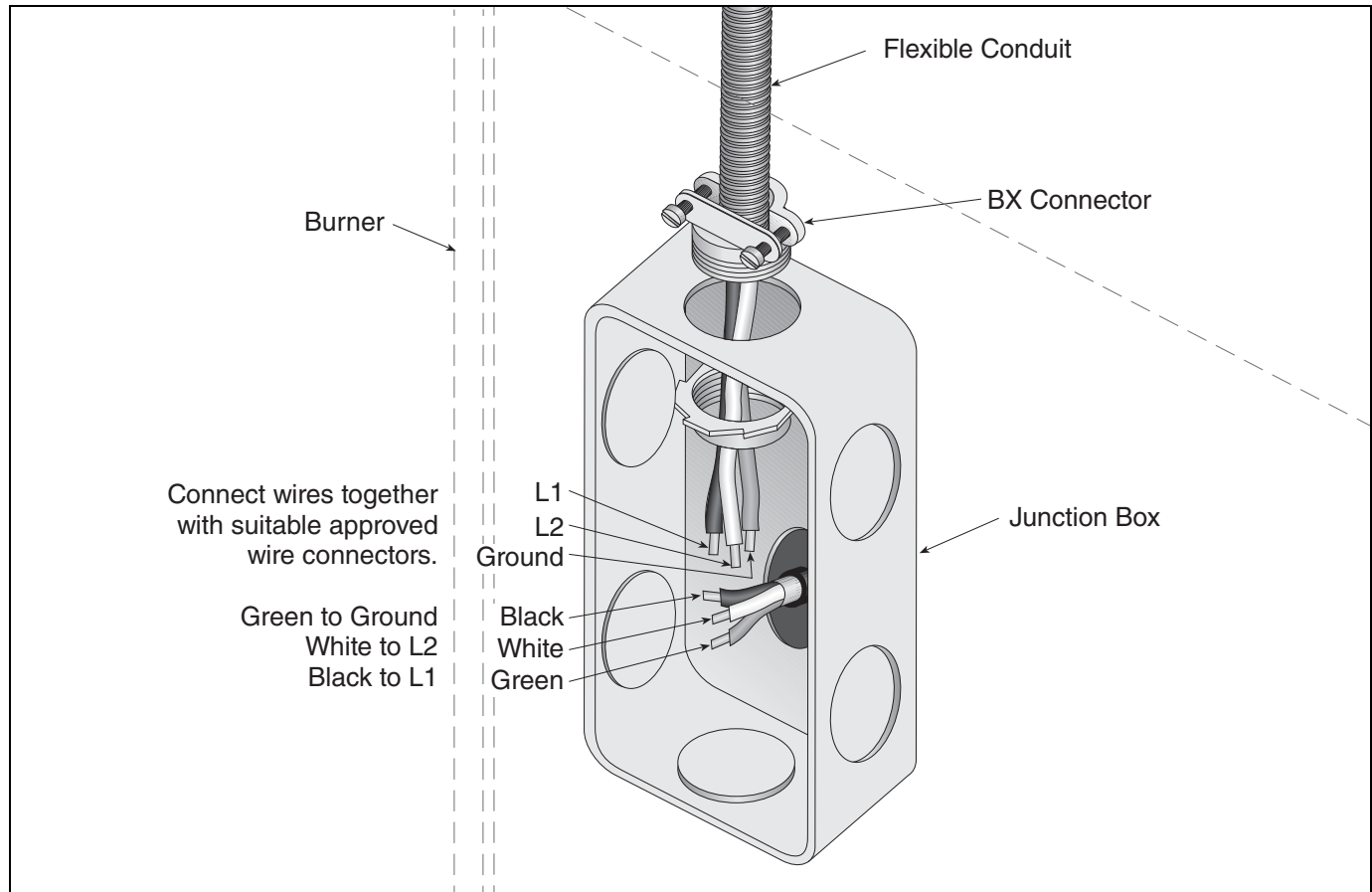


## 9.6 Ladder Wiring Diagram

**IMPORTANT:**

For field wiring into service junction box, or if any of the original wire supplied with the heater must be replaced, it must be replaced with wiring material having a temperature rating of at least 105° C (221° F) and 600 volts. For supply connections, use No. 14 AWG or larger wires.

### 9.7 Electrical Connection to the Heater



**IMPORTANT:** Junction box is not provided with heater.  
Conduit can also be attached directly to heater with wire junction made within the heater cabinet.

## SECTION 10: OPERATION AND MAINTENANCE


<b>⚠ WARNING</b>		
		
<b>Explosion Hazard</b>		
<p><b>Installation, service and annual inspection must be done by a contractor qualified in the installation and service of gas-fired heating equipment or your gas supplier.</b></p> <p><b>Turn off gas and electrical supplies before performing service or maintenance.</b></p> <p><b>Failure to follow these instructions can result in death, injury or property damage.</b></p>		

Read this manual carefully before installation, operation, or service of this equipment. All components are accessed via the door secured by four sheet metal screws. Opening the door exposes live electrical connections and hot components.

### 10.1 Pre-Start-Up Checks

All pre-start-up checks must be carried out before lighting the heater. Ensure that the heater and all controls are suitable for the gas, pressure and electrical supply to which they are to be connected.

#### 10.1.1 Louvers

<b>⚠ WARNING</b>

<b>Cut Hazard</b>
<p><b>Turn off gas and electrical supply before maintenance.</b></p> <p><b>Fan can start automatically at any time.</b></p> <p><b>Failure to follow these instructions can result in severe injury or product damage.</b></p>

Where fitted, the air delivery louvers need to be set during start-up to give the required air distribution (optional vertical louvers).

### 10.1.2 Electrical Checks

All pre-start-up checks must be carried out before start-up the heater.

1. Check that all site wiring is connected in accordance with the appropriate wiring diagram on Page 26, Section 9.5.

### 10.1.3 Gas Supply

All aspects of the gas installation including the gas meter must be inspected, tested for gas tightness and purged in accordance with local and national codes.

Ensure that the air is fully purged from the heater inlet pipe up to the main gas valve inlet test nipple.

### 10.1.4 Mechanical Checks

1. Check that the fan is free to run and delivery louvers are turned to give required air deflection.
2. Check that the flue (and air intake for separated combustion units) is installed in accordance with these instructions and local regulations.

## 10.2 Begin Start-Up

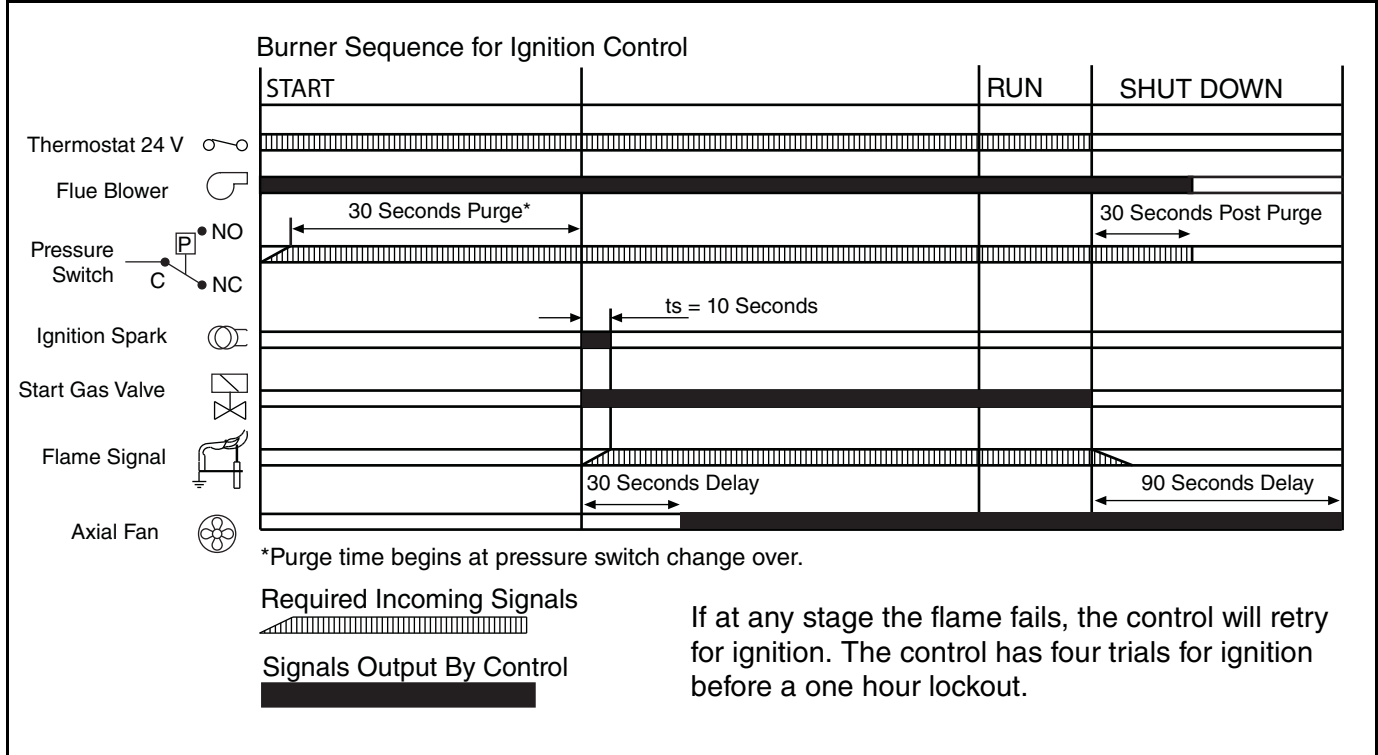
### 10.2.1 Before Operating the Heater

To ensure that all the controls are in safe working order, operate the heater for the first time with the isolating gas valve turned off and power supply turned on.

1. Turn off the isolating gas valve.
2. Turn up the thermostat above room temperature. The automatic ignition sequence will now begin as described on Page 30, Figure 16.

There will be no ignition of the burner and lockout will occur, which proves the controls are operating correctly.

**Figure 16: Automatic Burner Control Sequence**



**Figure 17: Gas Valve for Models UHA[X][S] 30 - 45**

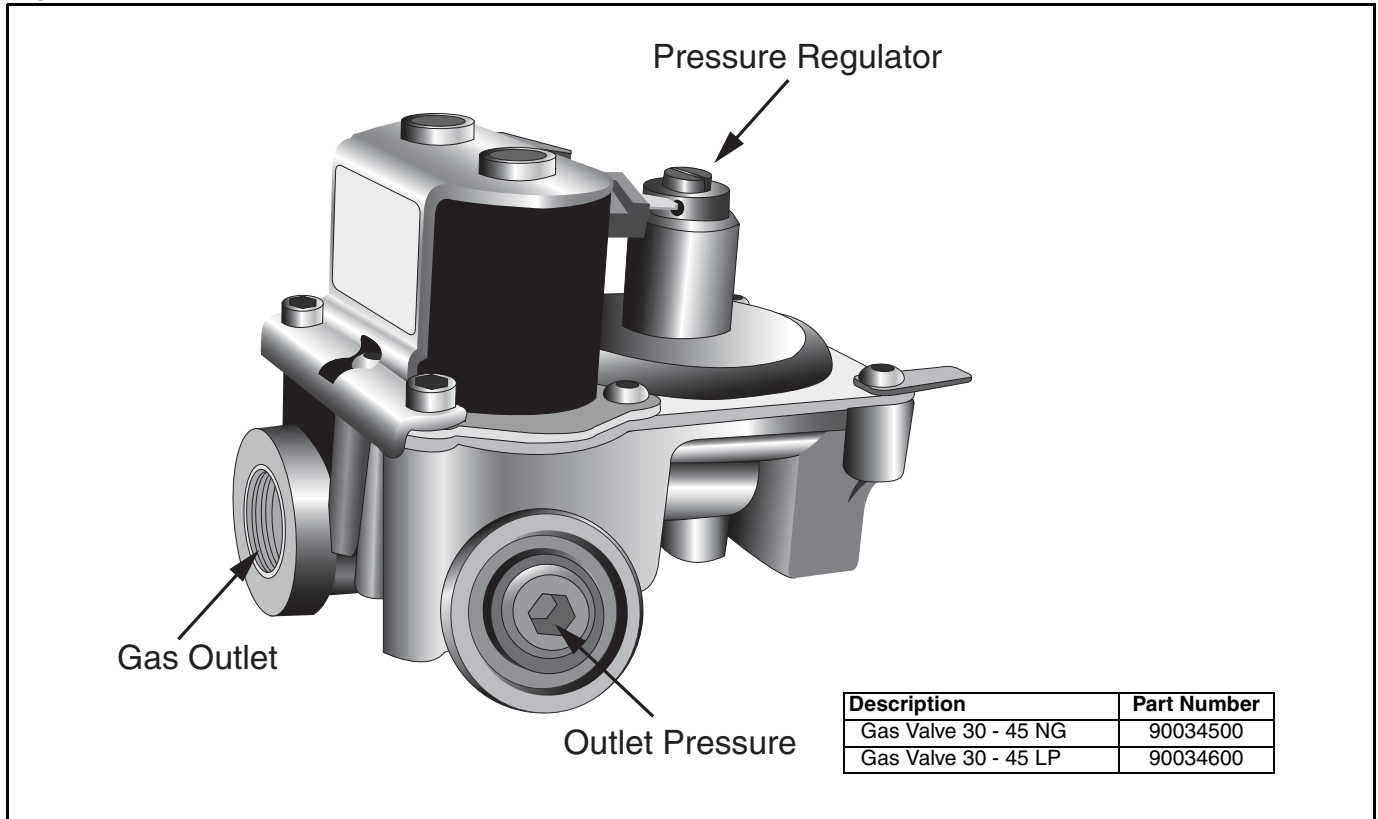
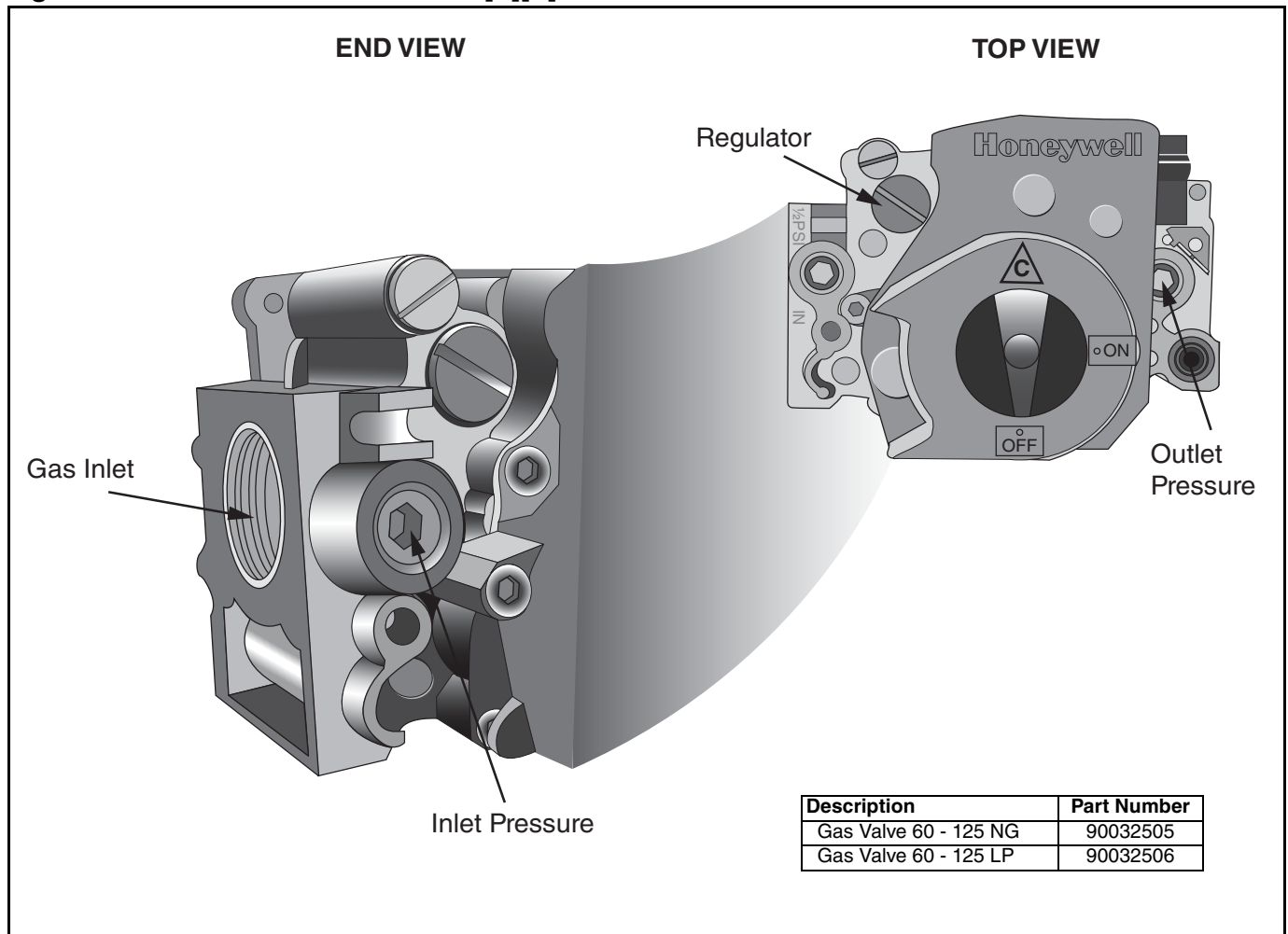


Figure 18: Gas Valve for Models UHA[X][S] 60 - 125



## 10.2.2 Start-Up the Gas Valve (All Gases)

### 10.2.2.1 Check Burner Gas Pressure

1. Remove the plug in the outlet (burner) pressure test point and connect a pressure tap and a manometer.
2. With the burner firing, measure the pressure on the manometer. To adjust the burner pressure, remove the regulator cover from the valve and turn the regulator adjustment screw to set the required burner pressure as stated in the Technical Data Tables for the correct gas and model on Page 50, Section 15.3.

**IMPORTANT:** If the correct burner pressure cannot be reached, then check the inlet pressure to the valve with the burner firing. See Technical Data Tables on Page 50, Section 15.3 for inlet pressure requirement.

**Do not continue to adjust the regulator if the pressure is not changing.**

If the inlet pressure is too low to allow correct burner

pressure setting, then the gas inlet pressure must be corrected before completing the start-up.

### Check Gas Rate

1. After burner pressure adjustment, allow the heater to operate for at least 15 minutes and then re-check settings. Adjust pressure setting if necessary.
2. Check gas flow rate at gas meter.
3. Turn off heater and electrical supply.
4. Remove the manometer and refit all covers to the valve and tighten the screw of the outlet pressure tap.

### 10.2.3 Pressure Switch

The pressure switch is factory pre-set for each model and is not adjustable.

### 10.2.4 Turning Off the Heater

Set the thermostat to the "OFF" position or lowest setting and the main burner will stop.

The fan will continue to run for 90 seconds.

**Do not use a disconnect switch for control of heater. Disconnect switch will turn off the fan.**

**Heat exchanger could be damaged. Warranty will not cover damage to the heat exchanger if operated improperly. Only use the disconnect switch for turning off heater for service or during off-season.**

### **10.2.5 External Controls**

External controls may include time switch, interlock switch, room thermostat and frost thermostat. Operate each control to ensure that they function correctly. Set the switches (if fitted) and thermostat(s) to the users' requirements.

### **10.3 Complete Start-Up**

Ensure that all covers are fitted correctly and all test points are properly sealed.

#### **10.3.1 Instruction to the User**

Explain the controls of the heater to the user including how to turn it on and off, using the controls fitted on site.

Give this manual to the user.

Ensure that the user is shown and understands the importance of maintaining clearances to combustibles *on Page 7, Figure 4* and the user instructions *on Page 6, Section 3 and Page 33, Section 11* and all warnings defined in this manual.

**SECTION 11: USER INSTRUCTIONS**

**⚠ WARNING**



**Explosion Hazard**

Installation, service and annual inspection must be done by a contractor qualified in the installation and service of gas-fired heating equipment or your gas supplier.

Turn off gas and electrical supplies before performing service or maintenance.

Failure to follow these instructions can result in death, injury or property damage.

**11.1 User Instructions**

The UHA[X][S] Series heaters are fully automatic and operate from the external controls fitted on site. The only user control at the heater is the Manual Reset Limit Switch - See Page 33, Section 11.3.1

**11.2 Heater Operation**

When the heater has been switched on by the thermostat installed on site, the main burner will automatically turn on.

The burner control box will control the safe ignition of the flame.

All heaters require a constant gas and electricity supply which must not be interrupted during the normal operation of this heater.

**11.3 Common User Controls**

**11.3.1 Manual Reset Limit Switch**

**⚠ WARNING**



**Explosion Hazard**

Do not make more than one attempt to restart the heater if manual reset limit switch locks out.

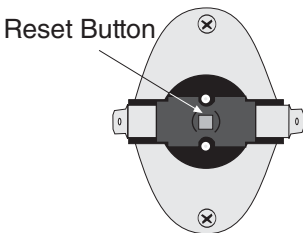
The vent or heat exchanger may be blocked.

The fault must be traced and repaired.

Failure to follow these instructions can result in death, injury or property damage.

On residentially approved models, the limit thermostat is located inside the access door of the heater. See Page 44, Section 14.3. This control protects against excessive heat build-up inside the burner compartment.

**Figure 19: Manual Reset Limit Switch**



To reset manual reset limit switch, press reset button. **NOTE:** To reset, the switch must be cool.

Description	Part Number
Manual Reset Limit Switch	90412106

**11.4 Lighting Instructions**

**11.4.1 To Turn On Heater**

1. Ensure that the electrical and gas supplies to the heater are on. Check that the on site controls are "ON".

**IMPORTANT:** The thermostat setting must be above the ambient temperature for the heater to operate.

2. The automatic firing sequence will begin as described on Page 30, Figure 16. The heater will now operate automatically under the control of the on site controls.

**11.4.2 To Turn the Heater Off**

Set the thermostat to the "OFF" position. The burner will turn off immediately. The fan will continue to run for 90 seconds. To restart, turn the thermostat above room temperature.

**11.5 Simple Troubleshooting**

Some possible reasons for the heater not operating are:

1. Gas supply not "ON".
2. Electricity supply not "ON".
3. The time and/or temperature controls are not "ON".
4. A limit switch may have operated. This may be caused by an interruption of the electrical supply, failure of the distribution fan or vent or heat exchanger blockage.

If a temperature limit switch persistently trips, there is a fault which must be investigated by a contractor qualified in the installation and service of gas-fired heating equipment.

**11.5.1 Simple Troubleshooting (Burner Faults)**

If the burner fails to ignite for any reason, it will retry for ignition (four trials total). After four unsuccessful ignition trials, the control will put the heater into lockout for one hour.

Lockout should not occur during normal operation of the heater and indicates there is a fault condition which must be corrected. There is an LED light on the ignition control that flashes codes to assist in fault correction. See Page 34, Figure 20 for LED indication codes.

**Figure 20: LED Diagnostic Codes**

LED INDICATION	FAULT MODE
Slow Flash	Normal Operation - No call for heat.
Fast Flash	Normal Operation - Call for heat.
2 Flashes	Ignition Lockout - No flame detected.
3 Flashes	Airflow Fault - Pressure switch open or closed.
4 Flashes	Temperature Limit or Manual Reset Limit Switch Open
5 Flashes	Flame Sense Error - Gas valve not energized.
Steady On	Internal Control Failure



## SECTION 12: SERVICING

<b>⚠ WARNING</b>		
		
<b>Explosion Hazard</b>		
<p><b>Installation, service and annual inspection must be done by a contractor qualified in the installation and service of gas-fired heating equipment or your gas supplier.</b></p> <p><b>Turn off gas and electrical supplies before performing service or maintenance.</b></p> <p><b>Failure to follow these instructions can result in death, injury or property damage.</b></p>		

**12.1 Servicing Instructions**

After start-up, the heater will require maintenance to be carried out annually. If the heater is used in a dirty or dusty area, more frequent maintenance may be required.

**IMPORTANT:** After any maintenance or repair work, always test fire the heater in accordance with the start-up instructions on *Page 29, Section 10 through Page 32, Section 10.3.1* to ensure all safety systems are in working order before leaving the heater to operate. Minor faults may be traced by using the troubleshooting charts on *Page 38, Section 13 through Page 41, Section 13.5*.

**IMPORTANT:** Check all gas pipes and pipe joints to ensure there are no cracks or gas leaks. Any cracks in the pipes or pipe joints must be repaired.


**IMPORTANT:** Inspect all suspended components and hardware. Ensure that they are in good condition, properly tightened, and corrosion free

**12.2 Burner Maintenance**

1. Open the door and remove the burner compartment cover. See *Page 43, Section 14.2*.
2. Clean any deposits from the main burner which may have formed in the injectors or venturi of the burner. See *Page 43, Section 14.2*.

3. Remove the ignition electrode and flame probe. Check condition of ignition electrode and flame probe. Clean off any deposits which may have been formed, check condition of ceramic insulators. Replace as required.

**12.3 Fan/Motor Assembly Maintenance**

<b>⚠ WARNING</b>

<b>Cut Hazard</b>
<p><b>Turn off gas and electrical supply before maintenance.</b></p> <p><b>Fan can start automatically at any time.</b></p> <p><b>Failure to follow these instructions can result in severe injury or product damage.</b></p>

The main fan bearings are permanently sealed and do not need lubrication. Before cleaning, turn off gas and electrical supply. Remove the fan and use a small brush or duster to clean the fan blades from each side. Replace fan when done.

**12.4 Heat Exchanger Maintenance**

The heat exchanger will remain clean unless a problem has developed with combustion. Inspect the heat exchanger. Look for signs of overheating at the front tubes which may indicate burner over firing or persistently low air flows.

**12.5 Gas Valve Maintenance**

No regular maintenance is required on this device. To change gas control valves, See *Page 42, Section 14.1*.

**Do not repair or disassemble gas valve.**

Replace faulty gas valves with replacement parts sold and supplied by Roberts-Gordon.

**12.6 Flue Blower**

The flue blower should not require maintenance. However, if the air pressure switch is causing burner lockout, then remove the flue blower from the vent box by unscrewing the three screws at the mounting plate. Remove the four screws attaching the mounting plate to the fan inlet (See *Page 46, Section 14.6*). Ensure that the fan is free to run and that the fan wheel is clean.

**12.7 Venting and Air Intake Pipe**

Inspect all venting and air intake pipe. Ensure that all seams are sealed and suspension points secure. Repair suspension points if any part of the venting or combustion air pipe is sagging. Check to make sure any insulation is not missing or in poor condition. Replace as required. Check all venting and air intake components to ensure they are in good condition, gas tight and corrosion-free.

**12.8 Maintenance Checklist**

<b>! WARNING</b>		
		
<b>Explosion Hazard</b>		
<p><b>Installation, service and annual inspection must be done by a contractor qualified in the installation and service of gas-fired heating equipment or your gas supplier.</b></p> <p><b>Turn off gas and electrical supplies before performing service or maintenance.</b></p> <p><b>Failure to follow these instructions can result in death, injury or property damage.</b></p>		

**Installation Code and Annual Inspections:** All installations and service of ROBERTS GORDON® equipment must be performed by a contractor qualified in the installation and service equipment sold and supplied by Roberts-Gordon and conform to all requirements set forth in the ROBERTS GORDON® manuals and all applicable governmental authorities pertaining to the installation, service and operation of the equipment. To help facilitate optimum performance and safety, Roberts-Gordon recommends that a qualified contractor annually inspect your ROBERTS GORDON® equipment and perform service where necessary, using only replacement parts sold and supplied by Roberts-Gordon.

<b>The Vicinity of the Heater</b>	<p>Do not store or use flammable objects, liquids or vapors near the heater. Immediately remove these items if they are present.</p> <p><i>See Page 6, Section 3.</i></p>
<b>Vehicles and Other Objects</b>	<p>Maintain the clearances to combustibles.</p> <p>Do not hang anything from, or place anything on, the heater.</p> <p>Make sure nothing is lodged in between the heat exchanger or in the louvers. Immediately remove objects in violation of the clearances to combustibles.</p> <p><i>See Page 6, Section 3.</i></p>
<b>Vent Pipe/Terminals</b>	<p>Venting must be intact. Using a flashlight, look for obstructions, cracks on the pipe, gaps in the sealed areas or corrosion.</p> <p>The area must be free of dirt and dust.</p> <p>Remove any carbon deposits or scale using a wire brush.</p> <p>If the vent terminal has a screen built in, remove any dirt, dust or deposits from the screen.</p> <p><i>See Page 21, Section 7.</i></p>

<b>Combustion Air Intake Pipe</b>	<p>Intake pipe and inlet must be intact. Look for obstructions, cracks on the pipe, gaps in the sealed areas or corrosion.</p> <p>The area must be free of dirt and dust.</p> <p>Clean and reinstall as required.</p>
<b>Heat Exchanger</b>	<p>Make sure there are no cracks.</p> <p>Make sure there is no sagging, bending or distortion.</p> <p>Clean or replace as required.</p> <p>See Page 22, Section 8.</p>
<b>Gas Line and Shut-off Valves</b>	<p>Check for gas leaks. See Page 22, Section 8.</p>
<b>Burner Observation Window</b>	<p>Make sure it is clean and free of cracks or holes.</p> <p>Clean and replace as required.</p>
<b>Flue Blower Scroll, Wheel and Motor</b>	<p>Compressed air or a vacuum cleaner may be used to clean dust and dirt.</p>
<b>Inshot Burners and Orifices</b>	<p>Clear obstructions (even spider webs will cause problems).</p> <p>Carefully remove any dust and debris from the burner.</p>
<b>Direct-Spark Igniter</b>	<p>Replace if there are cracked ceramics, excessive carbon residue, or erosion of the electrode.</p> <p>The electrode gap should be 1/8" (3.2 mm).</p>
<b>Thermostat</b>	<p>There should be no exposed wire or damage to the device or wiring.</p> <p>See Page 29, Section 10.</p>
<b>Suspension Points</b>	<p>Make sure the heater is hanging securely.</p> <p>Look for signs of wear on the suspension materials or ceiling.</p> <p>See Page 11, Figure 5.</p>
<b>Silicone Tubing</b>	<p>Ensure tight, secure fit on all pressure fittings at pressure switch, burner partition, and blower outlet.</p>
<b>Gas Valve</b>	<p>Verify that cap covering pressure regulator adjustment screw is secure and has not been tampered with.</p> <p>Verify all wiring connections.</p>
<b>Condensate Drain (when installed)</b>	<p>Flush drain and clear any obstructions.</p>
<b>Wall Tag</b>	<p>If wall tag is present, make sure it is legible and accurate. Please contact Roberts Gordon LLC or ROBERTS GORDON® independent distributor if you need a wall tag. See Page 5, Section 2.1.</p>

**SECTION 13: TROUBLESHOOTING**

**13.1 General**

**⚠ WARNING**



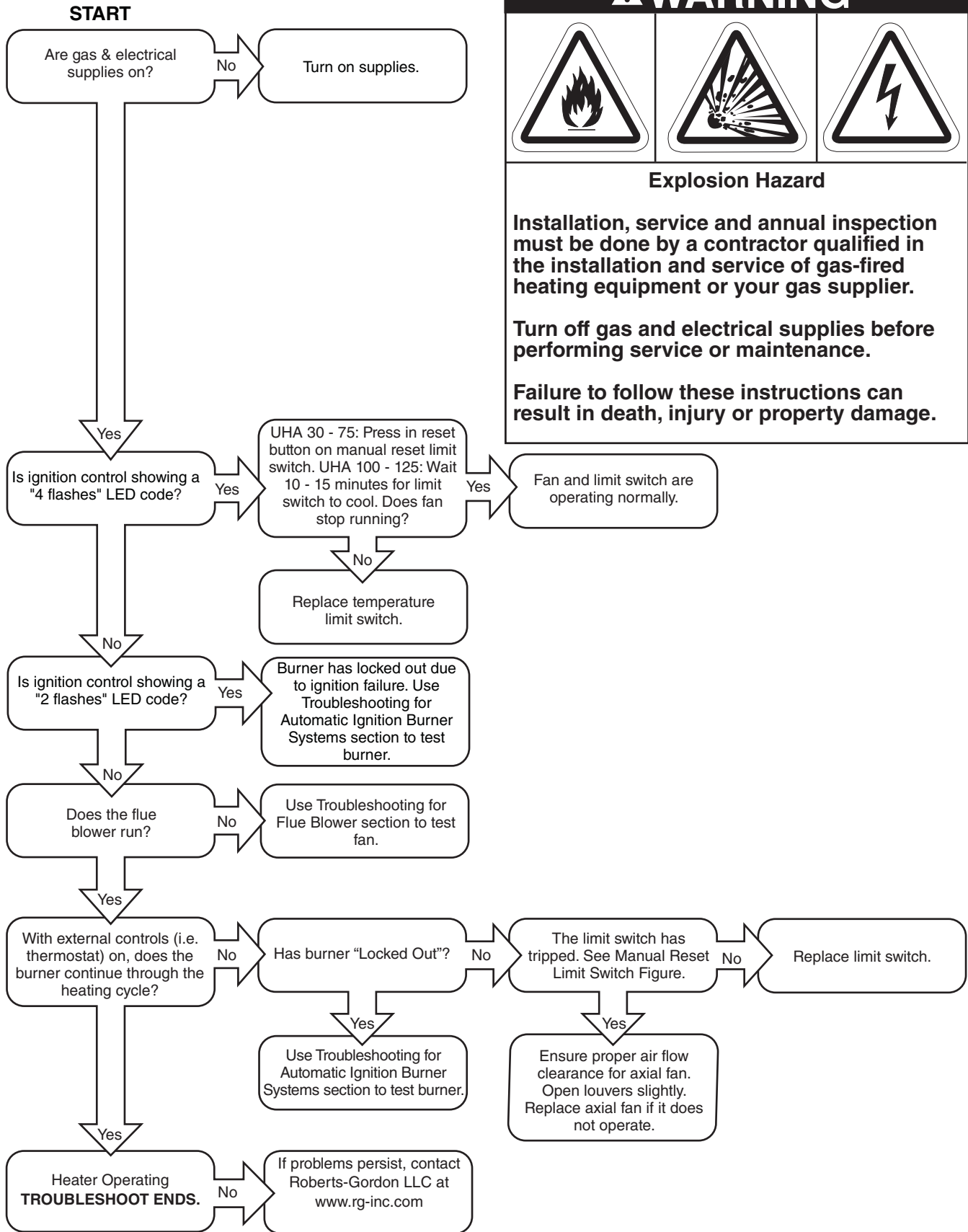


**Explosion Hazard**

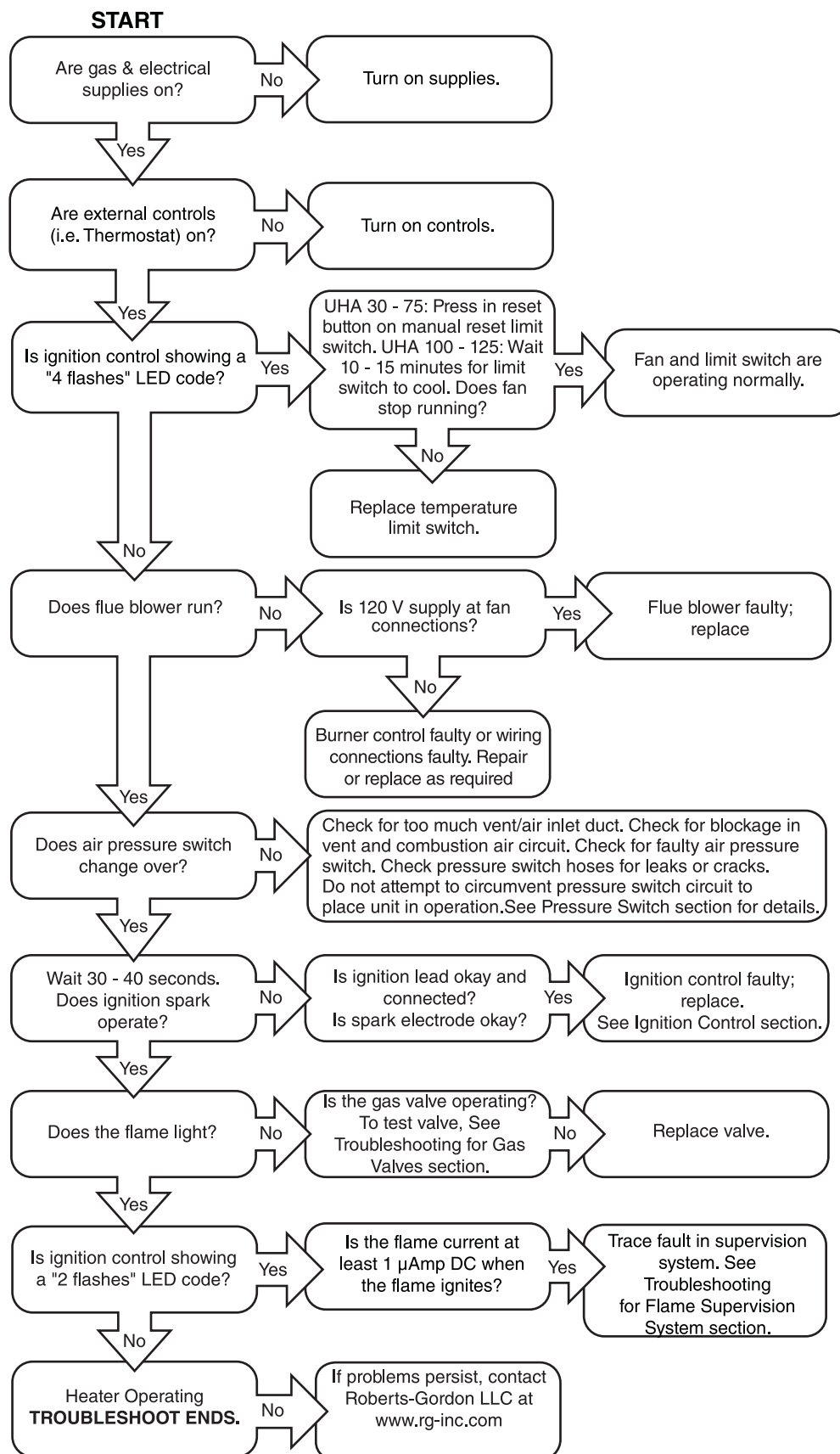
**Installation, service and annual inspection must be done by a contractor qualified in the installation and service of gas-fired heating equipment or your gas supplier.**

**Turn off gas and electrical supplies before performing service or maintenance.**

**Failure to follow these instructions can result in death, injury or property damage.**



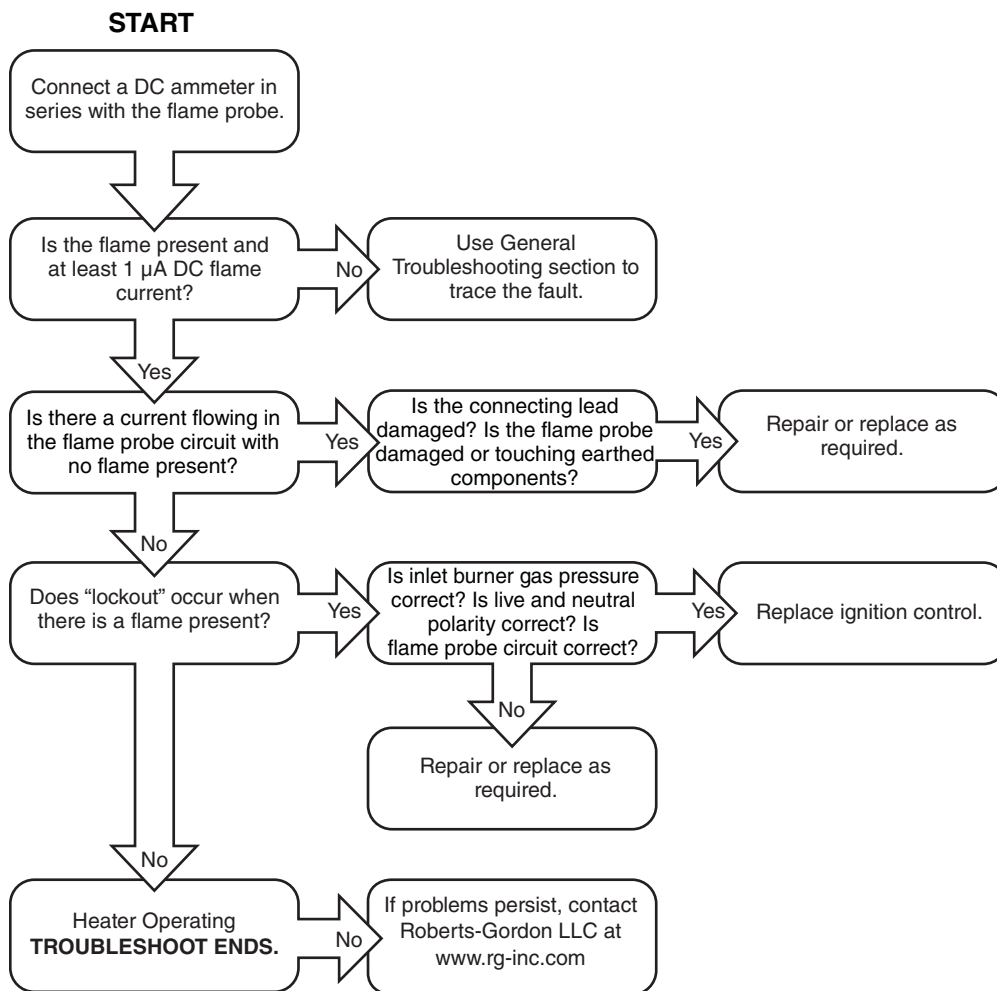
## 13.2 Troubleshooting For Automatic Ignition Burner Systems



For optimum heater performance, use only replacement parts sold and supplied by Roberts-Gordon.  
**Conduct start-up procedure as shown on Page 29, Section 10.**

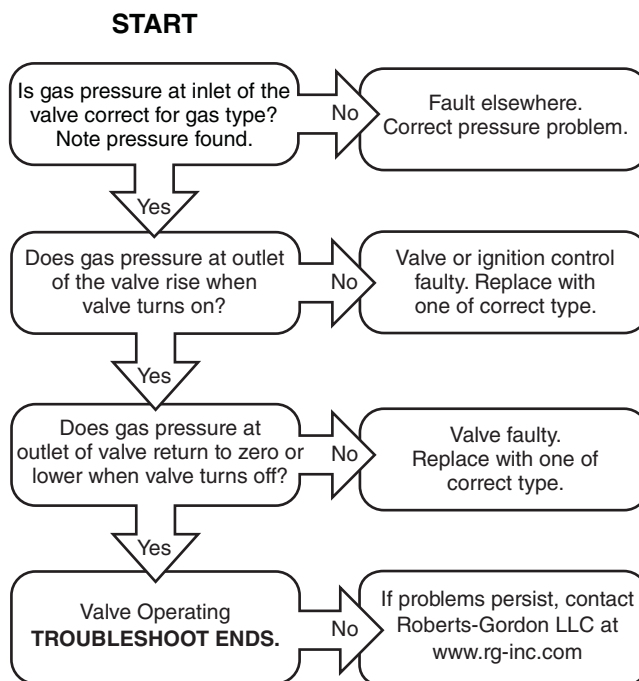
### 13.3 Troubleshooting for Flame Supervision System

To measure flame current, connect a 0 - 50  $\mu\text{A}$  DC meter in series with the flame probe. If the meter reads negative values, then reverse the test leads.

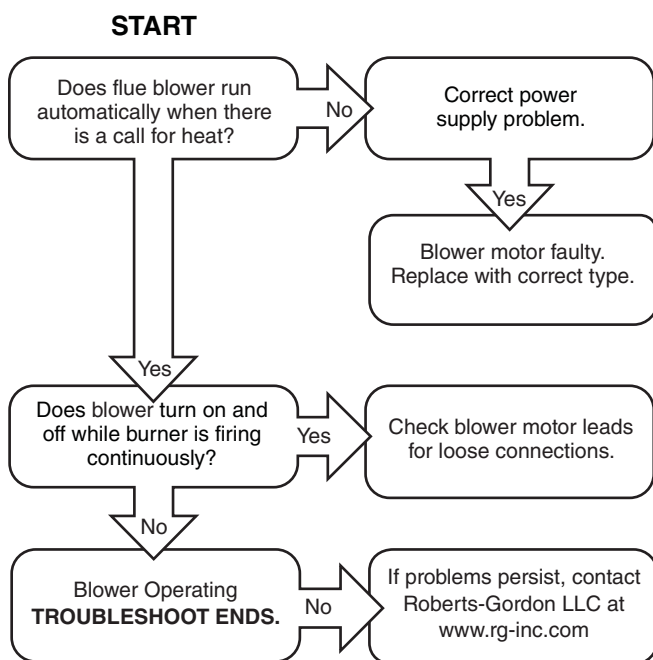


**NOTE:** Minimum flame probe current 1  $\mu\text{A}$  DC. Typical flame probe current 3-5  $\mu\text{A}$  DC.

### 13.4 Troubleshooting for Gas Valves



### 13.5 Troubleshooting for Flue Blower



For optimum heater performance, use only replacement parts sold and supplied by Roberts-Gordon.  
**Conduct start-up procedure as shown on Page 29, Section 10.**

**SECTION 14: REPLACEMENT PARTS**

⚠ WARNING





Explosion Hazard

Installation, service and annual inspection must be done by a contractor qualified in the installation and service of gas-fired heating equipment or your gas supplier.

Turn off gas and electrical supplies before performing service or maintenance.

Failure to follow these instructions can result in death, injury or property damage.

**14.1 Gas Valve**

Remove the gas supply pipe at the heater inlet. Follow steps in *Section 14.2* and *Section 14.2.1* to remove gas valve/manifold.

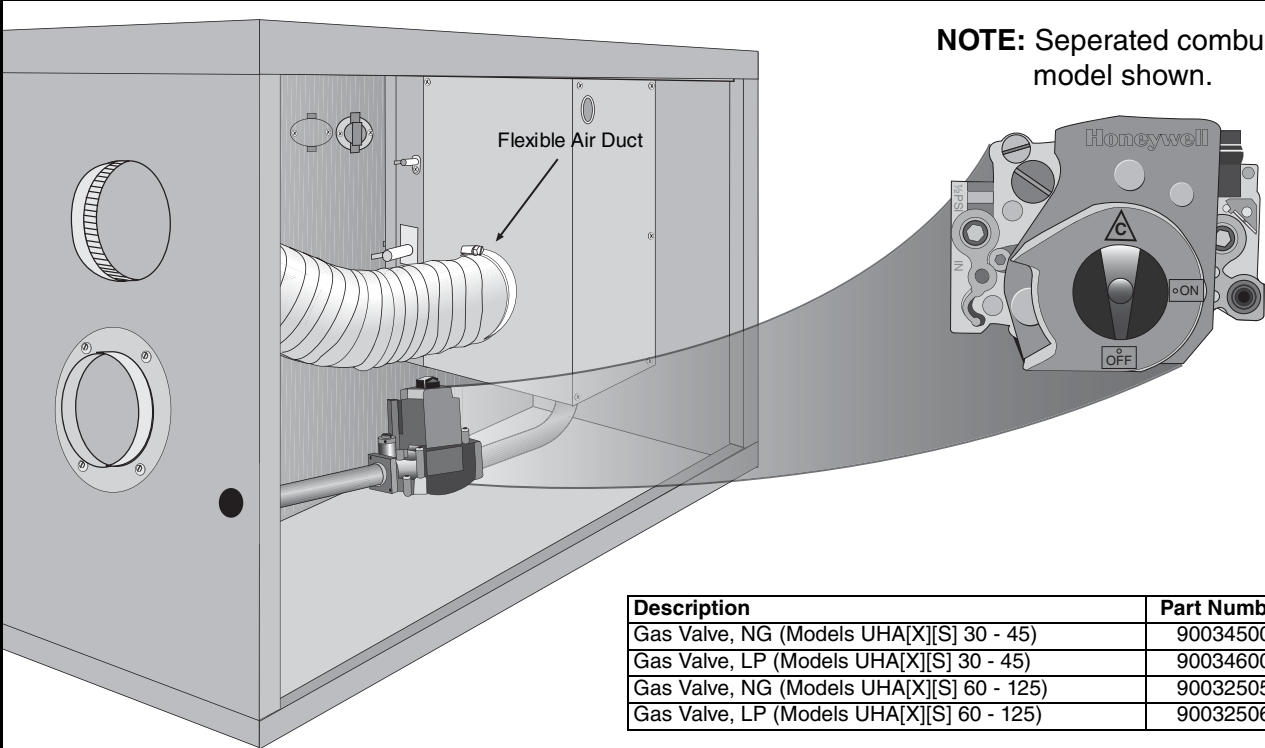
Replace in reverse order. Verify that the gas flow direction of the valve is correct. Use a minimum amount of gas seal on the thread joint. Check that all the joints are leak free. Reset gas valve. See *Page 31, Section 10.2.2*.

**IT IS IMPORTANT THAT ONLY THE CORRECT GAS VALVE IS USED WHEN REPLACING THESE CONTROLS.**

See warnings and notes on *Page 35, Section 12* before removing or replacing parts.

**Burner Components**

All serviceable burner parts are accessed by the door on the side of the heater. Remove the sheetmetal screws.

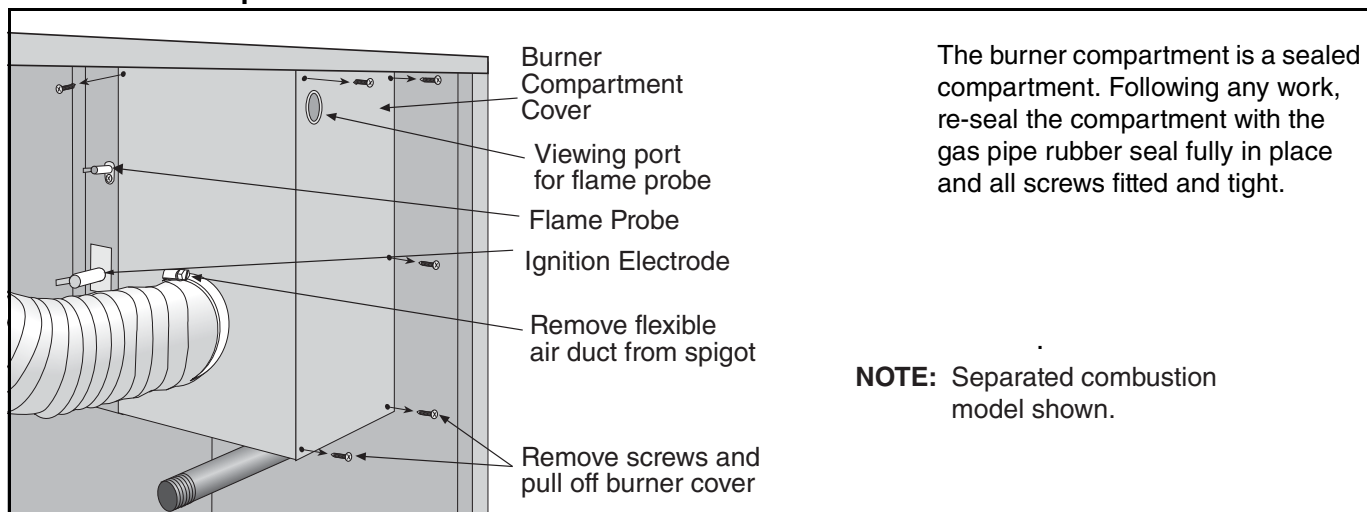


**NOTE:** Separated combustion model shown.

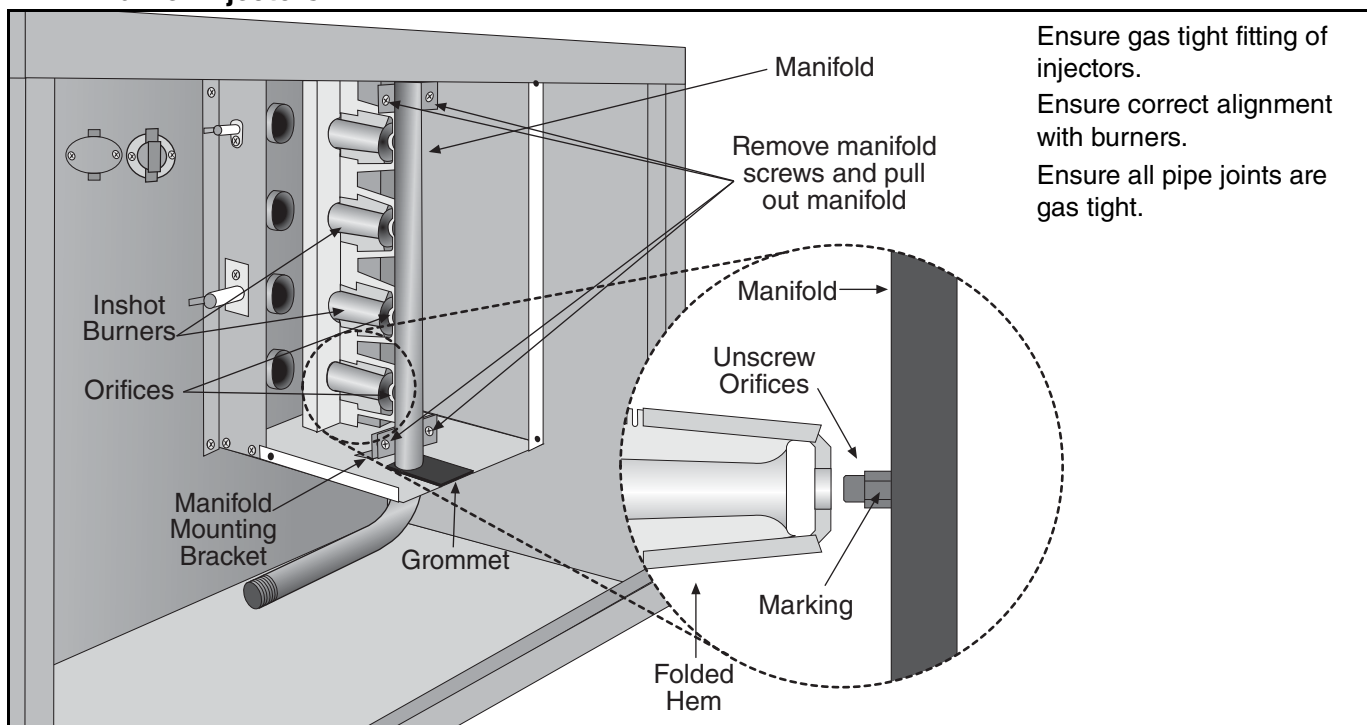
Description	Part Number
Gas Valve, NG (Models UHA[X][S] 30 - 45)	90034500
Gas Valve, LP (Models UHA[X][S] 30 - 45)	90034600
Gas Valve, NG (Models UHA[X][S] 60 - 125)	90032505
Gas Valve, LP (Models UHA[X][S] 60 - 125)	90032506



## 14.2 Burner Compartment

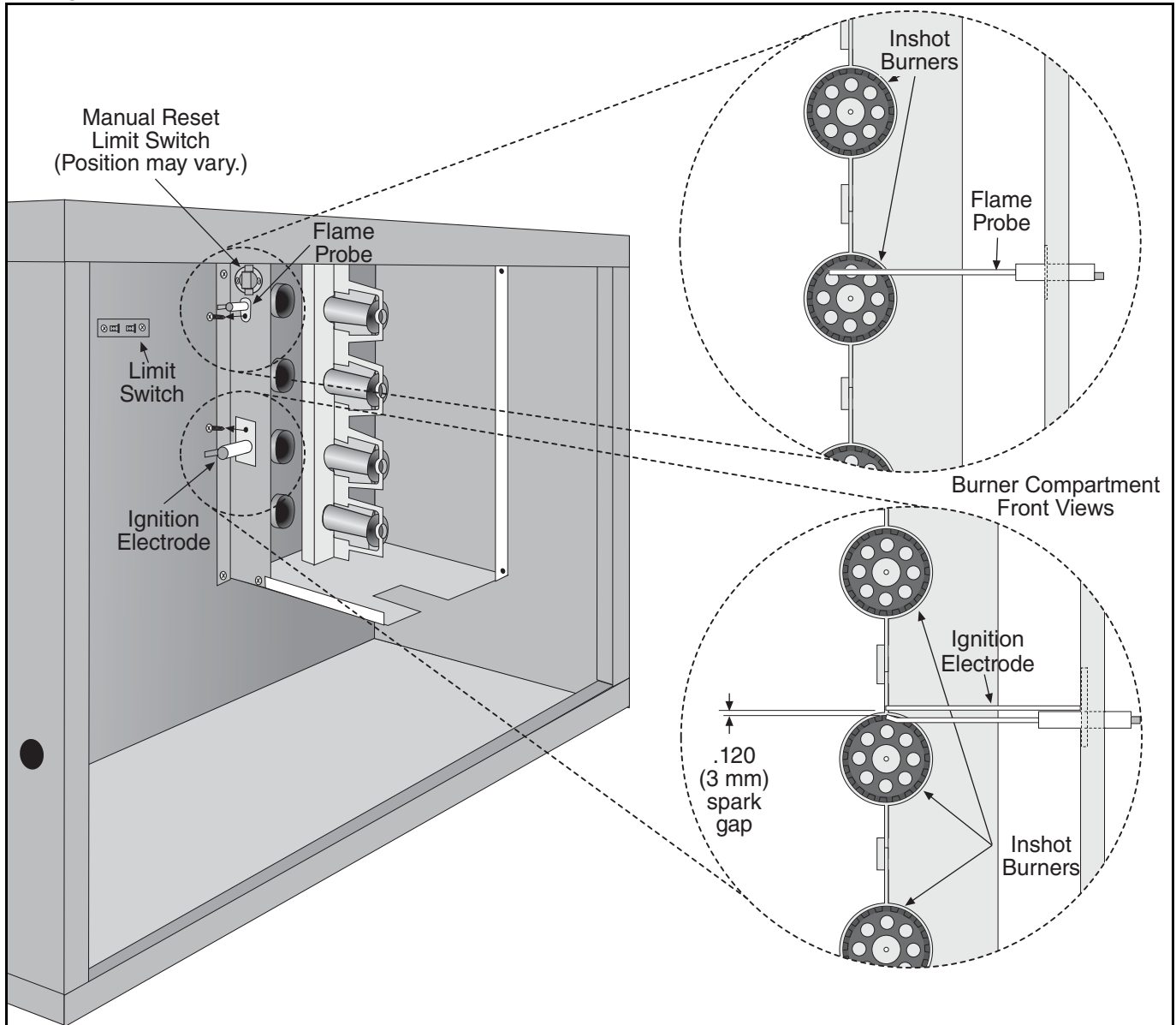


### 14.2.1 Burner Injectors



MODEL	UHA[X][S] 30	UHA[X][S] 45	UHA[X][S] 60	UHA[X][S] 75	UHA[X][S] 100	UHA[X][S] 125
Orifice Quantity	2	3	4	5	6	7
<b>Natural Gas (G20)</b>						
Orifice Marking	49	49	49	49	46	46
P/N	91930049	91930049	91930049	91930049	91930046	91930046
<b>Propane (G31)</b>						
Orifice Marking	56	56	56	1.15 mm	1.25 mm	1.25 mm
P/N	91930056	91930056	91930056	91930115	91930125	91930125

### 14.3 Ignition Electrode and Flame Probe



To replace the electrode or flame probe, remove the electrical lead and screw. Pull out from mounting. Refit in reverse ensuring that the gap to burner is as shown in the front view of the burner compartment.

Description	Part Number	Qty
Spark Electrode	90427411	1
Automatic Ignition Flame Probe	90439300	1
Transformer	90436900K	1
Ignition Module	90434008	1
Inshot Burners UHA[X][S] 30	92000002	2
Inshot Burners UHA[X][S]45	92000002	3
Inshot Burners UHA[X][S] 60	92000002	4
Inshot Burners UHA[X][S] 75	92000002	5
Inshot Burners UHA[X][S] 100	92000002	6
Inshot Burners UHA[X][S] 125	92000002	7
Limit Switch	90412104	1
Manual Reset Limit Switch	90412106	1

### 14.4 Heat Exchanger

The heat exchanger consists of a four-pass design with 1.5" outer diameter [aluminized steel][409 stainless steel] tube. The tube plates are made of [aluminized steel][409 stainless steel]. The tube supports are made of [galvannealed steel] [409 stainless steel].

### 14.5 Louver and Louver Springs

Horizontal Louvers

Vertical Louvers

For models UHA[X][S] 60 and UHA[X][S] 75, horizontal louvers are re-used.

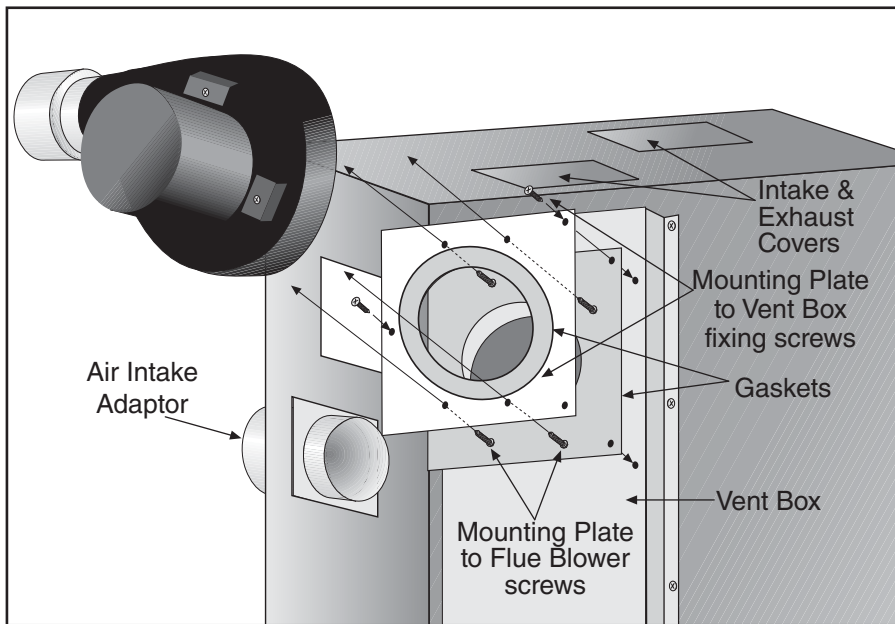
Description	UHA[X][S] 30 - 45	UHA[X][S] 60 - 75	UHA[X][S] 100 - 125
Horizontal Louvers P/N	11111900		
Spring P/N	91901200		
Quantity	3	5	7

Description	Part Number	Qty.
<b>Vertical Louver Kit UHA[X][S] 30 &amp; UHA[X][S] 45</b>	<b>12011003K</b>	
Vertical Louver Bracket	-	2
UHA[X][S] 30 - 45 Vertical Louvers	-	4
Louver Spring	-	5
Instruction Sheet	-	2
#10 Screw	-	1
#10 Screw	-	4

Description	Part Number	Qty.
<b>Vertical Louver Kit UHA[X][S] 60 &amp; UHA[X][S] 75</b>	<b>12011005K</b>	
Vertical Louver Bracket	-	2
UHA[X][S] 60 - 75 Vertical Louvers	-	5
Instruction Sheet	-	1
#10 Screw	-	4

Description	Part Number	Qty.
<b>Vertical Louver Kit UHA[X][S] 100 &amp; UHA[X][S] 125</b>	<b>12011004K</b>	
Vertical Louver Bracket	-	2
UHA[X][S] 100 - 125 Vertical Louvers	-	5
Instruction Sheet	-	1
#10 Screw	-	4

### 14.6 Flue Blower Vertical Installation

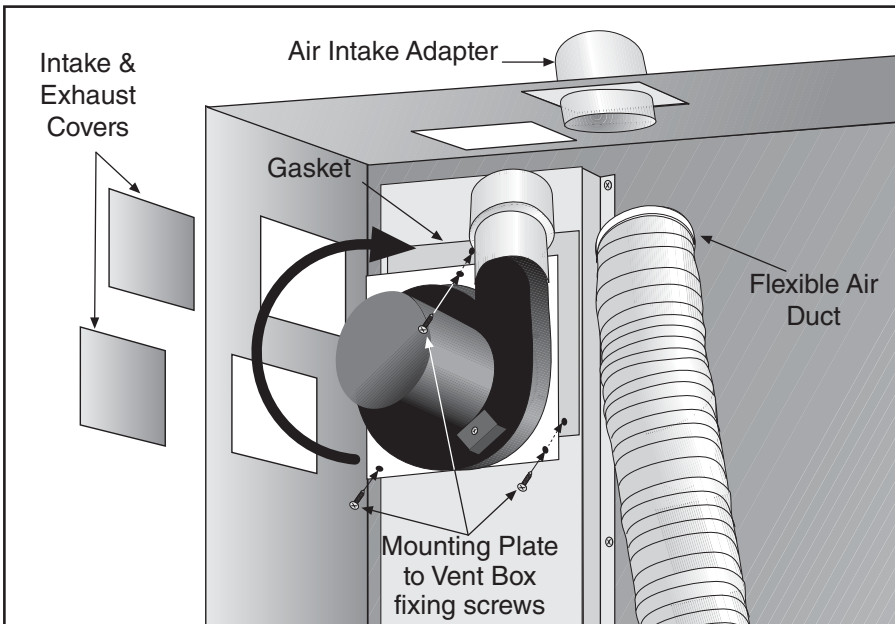


To remove the blower, remove screws securing the fan and mounting plate to the vent box.

To remove the blower from the mounting plate, remove screws.

Refit in reverse order. To change the vent and air intake orientation from back to top, remove the blower and mounting plate as above.

Remove intake (if applicable) and exhaust covers from top of the heater.



Rotate the blower, mounting plate and gasket clockwise until the flue adapter lines up with the top hole. Secure screws.

If applicable, remove the flexible air duct from the air intake adaptor on the back.

If applicable, remove the air intake adapter from the back of the heater and install in the appropriate hole on top. Reconnect the flexible air duct.

Install intake and exhaust covers over the back holes.

**NOTE:** Separated combustion model shown.

MODEL	UHA[X][S] 30 -75	UHA[X][S] 100 - 125
Flue Blower P/N	90710404	90710405


**IT IS IMPORTANT THAT ONLY THE CORRECT FLUE BLOWER SPECIFIED FOR EACH MODEL TYPE IS USED WHEN REPLACING THESE ITEMS.**

Carry out a start-up after working on or changing an flue blower. See Page 33, Section 11.

### 14.7 Pressure Switch

Pull off 3 way connector. Spring open plastic clips of mounting cradle. Replace with correct type of pressure switch for model. The pressure switches are color coded for each pressure setting. Carry out a start-up after working on or changing a pressure switch. See Page 29, Section 10.

**! WARNING**



**Carbon Monoxide Hazard**

**Use correct pressure switch specified for each model according to manual.**

**Use of incorrect pressure switch or disabling pressure switch circuit could cause unsafe condition.**

**Failure to follow these instructions can result in death or serious injury.**

MODEL	UHA[X][S] 30	UHA[X][S] 45	UHA[X][S] 60	UHA[X][S] 75	UHA[X][S] 100	UHA[X][S] 125
Pressure Switch Kit P/N	90439801	90439810	90439802	90439810	90439810	90439803
Color Code	pink	black	yellow	black	black	gray
Set Point in. wc	.23	.35	.32	.35	.35	.41
Pressure Switch Snap Ring P/N	90439850	90439850	90439850	90439850	90439850	90439850

### 14.8 Ignition Control

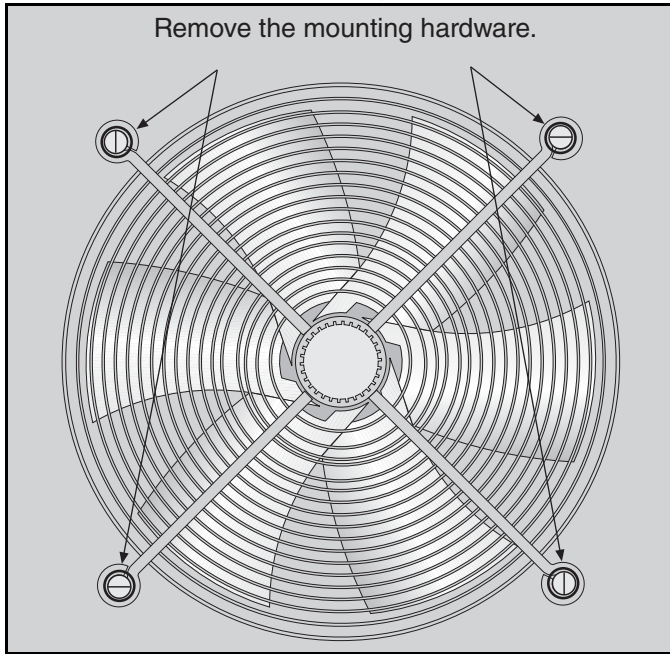
The control mounts to the heat exchanger plate. Pull out ignition cable and wiring from board, noting their positions. Release the four mounting standoffs. Refit in reverse. Ensure correct location of ignition cable and all other wiring.

### 14.9 Axial Fan/Guard/Motor Assembly

The axial fan unit for the heater is supplied completely assembled and balanced.

MODEL	UHA[X][S] 30	UHA[X][S] 45	UHA[X][S] 60	UHA[X][S] 75	UHA[X][S] 100	UHA[X][S] 125
Axial Fan Guard	91901103	91901103	91901102	91901102	91901102	91901102
Axial Fan Motor	90600104	90600104	90600105	90600105	90600106	90600106
Axial Fan Blade	90709004	90709003	90709002	90709001	90709001	90709001

### 14.9.1 Fan Removal and Replacement



Description	Part Number	Quantity
Axial Fan UHA[X][S] 30	12011910	1
Axial Fan UHA[X][S] 45	12011911	1
Axial Fan UHA[X][S] 60	12011920	1
Axial Fan UHA[X][S] 75	12011921	1
Axial Fan UHA[X][S] 100 and UHA[X][S] 125	12011922	1

### 14.9.2 To Replace the Fan Assembly

To replace the fan assembly, reverse the procedure shown above.

- Check that the fan blades are free to rotate before turning on the power to the fan.
- Strictly comply with the color code of the fan wires to ensure correct operation. See *Page 26, Section 9.5* wiring diagram.
- Use only replacement parts sold and supplied by Roberts-Gordon.

## 14.10 Limit Switches

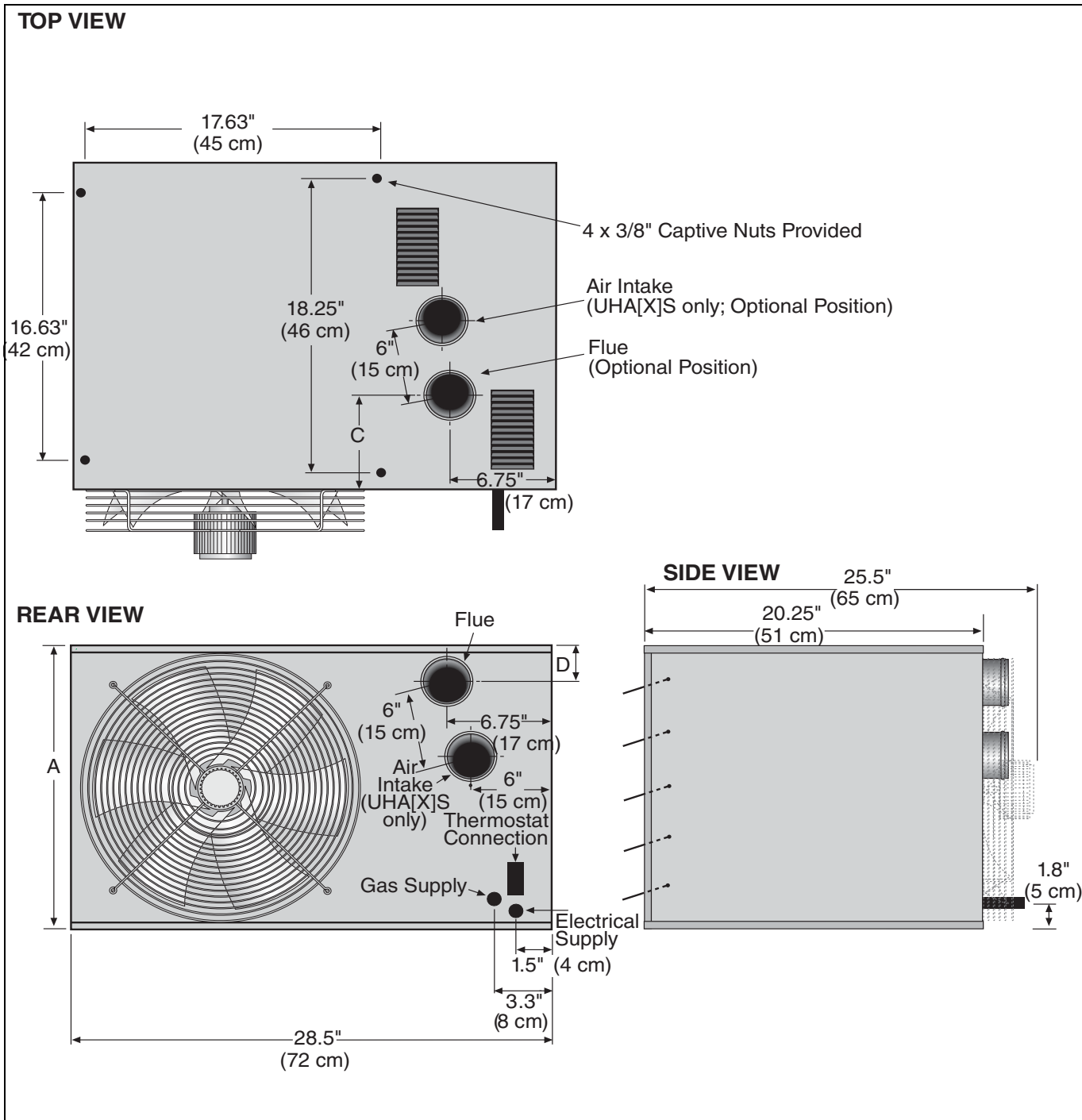
### 14.10.1 Removal and Replacement

1. Remove the electrical connections to the switch.
2. Unscrew the two screws securing the switch.
3. Fit a new switch with two screws.
4. Reconnect the electrical connections and test operation.

**SECTION 15: SPECIFICATIONS**

**15.1 Dimension Data**

MODEL		UHA[X][S] 30	UHA[X][S] 45	UHA[X][S] 60	UHA[X][S] 75	UHA[X][S] 100	UHA[X][S] 125
'A' Height	in (cm)	12 (30.48)	12 (30.48)	17.75 (45.09)	17.75 (45.09)	23 (58.42)	23 (58.42)
'C' Center of Flue [Top Option]	in (cm)	5.2 (13.21)	5.2 (13.21)	5.2 (13.21)	5.2 (13.21)	6.9 (17.53)	6.9 (17.53)
'D' Center of Flue	in (cm)	2.5 (6.35)	2.5 (6.35)	2.5 (6.35)	2.5 (6.35)	2.5 (6.35)	2.5 (6.35)
Recommended Mounting Height to Heater Base	ft (m)	10 (3.05)	10 (3.05)	12 (3.66)	12 (3.66)	20 (6.10)	20 (6.10)



**15.2 General Technical Data Table (All Models)**

	Model	UHA[X][S] 30	UHA[X][S]4 5	UHA[X][S] 60	UHA[X][S] 75	UHA[X][S] 100	UHA[X][S] 125
<b>Low Profile UHA[X][S] Axial Fans</b>							
Full Load Amps @ 115 V	A	3.0	3.0	4.1	4.1	5.8	5.8
Air Volume	CFM	691	691	1376	1376	1902	1902
<b>Flue and Air Intake</b>							
Flue and Air Intake Size	in (cm)	4 (10) - All Models					
*Maximum Straight Flue/Air Intake	ft (m)	25 (7.6)	25 (7.6)	25 (7.6)	25 (12.2)	40 (12.2)	40 (12.2)

\*Do not exceed the maximum length of flue stated or heater may not operate properly.

**15.3 Technical Data Table (All Models)**

	Model	UHA[X][S] 30	UHA[X][S] 45	UHA[X][S] 60	UHA[X][S] 75	UHA[X][S] 100	UHA[X][S] 125
Total Input	(Btu/h) x (1000)	30	45	60	75	100	125
Total Output	(Btu/h) x (1000)	24.6	36.9	49.2	61.5	82	102.5
Efficiency	%	82 - All Models					
<b>Natural Gas (G20) Data - Inlet Pressure 5.0 in wc Min., 14 in wc Max.</b>							
Burner Pressure	in wc	3.7	3.6	3.7	3.5	2.6	3.3
<b>LPG / Propane (G31) Data - Inlet Pressure 12.0 in wc Min., 14 in wc Max.</b>							
Burner Pressure	in wc	9.4	9.6	9.6	10.0	9.1	10.0



**SECTION 16: ROBERTS GORDON® COMBAT® UHA-SERIES WARRANTY****ROBERTS GORDON® WILL PAY FOR:**

Within 24 months from date of purchase by buyer or 27 months from the date of shipment by Roberts-Gordon (whichever comes first), replacement parts will be provided free of charge for any part of the product which fails due to a manufacturing or material defect.

Roberts-Gordon will require the part in question to be returned to the factory. Roberts-Gordon will, at its sole discretion, repair or replace after determining the nature of the defect and disposition of part in question.

ROBERTS GORDON® Replacement Parts are warranted for a period of 18 months from date of shipment from Roberts-Gordon or the remaining ROBERTS GORDON® COMBAT® UHA-Series warranty.

**ROBERTS GORDON® WILL NOT PAY FOR:**

Service trips, service calls and labor charges.

Shipment of replacement parts.

Claims where the total price of the goods have not been paid.

Damage due to:

- Improper installation, operation or maintenance.
- Misuse, abuse, neglect, or modification of the ROBERTS GORDON® COMBAT® UHA-Series in any way.
- Use of the ROBERTS GORDON® COMBAT® UHA-Series for other than its intended purpose.
- Incorrect gas or electrical supply, accident, fire, floods, acts of God, war, terrorism, or other casualty.
- Improper service, use of replacement parts or accessories not specified by Roberts-Gordon.
- Failure to install or maintain the ROBERTS GORDON® COMBAT® UHA-Series as directed in the Installation, Operation and Service manual.
- Relocation of the ROBERTS GORDON® COMBAT® UHA-Series after initial installation
- The use of the ROBERTS GORDON® COMBAT® UHA-Series in a corrosive atmosphere containing contaminants.
- The use of the ROBERTS GORDON® COMBAT® UHA-Series in the vicinity of a combustible or explosive material.
- Any defect in the ROBERTS GORDON® COMBAT® UHA-Series arising from a drawing, design, or specification supplied by or on behalf of the consumer.
- Damage incurred during shipment. Claim must be filed with carrier.

**WARRANTY IS VOID IF:**

The ROBERTS GORDON® COMBAT® UHA-Series is not installed by a contractor qualified in the installation and service of gas-fired heating equipment.

You cannot prove original purchase date and required annual maintenance history.

The data plate and/or serial number are removed, defaced, modified or altered in any way.

The ownership of the ROBERTS GORDON® COMBAT® UHA-Series is moved or transferred. This warranty is nontransferable.

Roberts-Gordon is not permitted to inspect the damaged controller and/or component parts.

**READ YOUR INSTALLATION, OPERATION AND SERVICE MANUAL**

If you have questions about your controller, contact your installing professional. Should you need Replacement Parts or have additional questions, call or write:

**Roberts-Gordon**

1250 William Street

P.O. Box 44

Buffalo, New York 14240-0044

716.852.4400

**On the web at:** [www.rg-inc.com](http://www.rg-inc.com)

**Roberts-Gordon' liability, and your exclusive remedy, under this warranty or any implied warranty (including the implied warranties of merchantability and fitness for a particular purpose) is limited to providing replacement parts during the term of this warranty.** Some jurisdictions do not allow limitations on how long an implied warranty lasts, so this limitation may not apply to you. There are no rights, warranties or conditions, expressed or implied, statutory or otherwise, other than those contained in this warranty.

**Roberts-Gordon shall in no event be responsible for incidental or consequential damages or incur liability for damages in excess of the amount paid by you for the ROBERTS GORDON® COMBAT® UHA-Series .**

Some jurisdictions do not allow the exclusion or limitation of incidental or consequential damages, so this limitation or exclusion may not apply to you. This warranty gives you specific legal rights, and you may also have other rights which vary from jurisdiction to jurisdiction.

Roberts-Gordon shall not be responsible for failure to perform under the terms of this warranty if caused by circumstances out of its control, including but not limited to war, fire, flood, strike, government or court orders, acts of God, terrorism, unavailability of supplies, parts or power. No person is authorized to assume for Roberts-Gordon any other warranty, obligation or liability.

**LIMITATIONS ON AUTHORITY OF REPRESENTATIVES:**

No representative of Roberts-Gordon, other than an Executive Officer, has authority to change or extend these provisions. Changes or extensions shall be binding only if confirmed in writing by Roberts-Gordon's duly authorized Executive Officer.





# OWNER WARRANTY REGISTRATION CARD

**Mail or Fax to:**  
Roberts Gordon LLC • 1250 William Street, P.O. Box 44 • Buffalo, NY 14240-0044 • Phone: 716-852-4400 • Fax: 716-852-0854  
Toll Free: 800-828-7450 • www.rg-inc.com

**About the Owner:**

Name: \_\_\_\_\_  
Address: \_\_\_\_\_ City: \_\_\_\_\_ State: \_\_\_\_\_ Zip Code: \_\_\_\_\_  
Phone: \_\_\_\_\_ Fax: \_\_\_\_\_ E-mail: \_\_\_\_\_

**About the Installer:**

Name: \_\_\_\_\_  
Address: \_\_\_\_\_ City: \_\_\_\_\_ State: \_\_\_\_\_ Zip Code: \_\_\_\_\_  
Phone: \_\_\_\_\_ Fax: \_\_\_\_\_ E-mail: \_\_\_\_\_

**Purchased From (if different than installer):**

Name: \_\_\_\_\_  
Address: \_\_\_\_\_ City: \_\_\_\_\_ State: \_\_\_\_\_ Zip Code: \_\_\_\_\_  
Phone: \_\_\_\_\_ Fax: \_\_\_\_\_ E-mail: \_\_\_\_\_

**About your Heater:**

Model#: \_\_\_\_\_ Serial #: \_\_\_\_\_ Fuel: \_\_\_\_\_ Installation Date: \_\_\_\_\_

**Type of Installation (check one):**

- Automotive       Manufacturing       Warehouse       Recreational       Aircraft
  - Public Building       Office       Retail       Agricultural       Other \_\_\_\_\_
- 

**Installation Code and Annual Inspections:** All installations and service of ROBERTS GORDON® equipment must be performed by a contractor qualified in the installation and service of equipment sold and supplied by Roberts-Gordon and conform to all requirements set forth in the ROBERTS GORDON® manuals and all applicable governmental authorities pertaining to the installation, service and operation of the equipment.

To help facilitate optimum performance and safety, Roberts-Gordon recommends that a qualified contractor annually inspect your ROBERTS GORDON® equipment and perform service where necessary, using only replacement parts sold and supplied by Roberts-Gordon.

**These products are not approved for residential use, except for models UHA[X][S] 30 - UHA[X][S] 75.**

© 2008 Roberts-Gordon LLC - All rights reserved. No part of this work covered by the copyrights herein may be reproduced or copied in any form or by any means – graphic, electronic, or mechanical, including photocopying, recording, taping, or information storage and retrieval systems – without written permission of Roberts Gordon LLC.





Attach this information to the wall near the ROBERTS GORDON® heater



Read the Installation, Operation and Service Manual thoroughly before installation, operation or service.

**OPERATING INSTRUCTIONS**

1. STOP! Read all safety instructions on this information sheet.
2. Open the manual gas valve in the heater supply line.
3. Turn on electric power to the heater.
4. Set the thermostat to desired setting (above ambient temperature).  
The automatic starting sequence begins.

**TO TURN OFF THE HEATER**

1. Turn the thermostat/time switch to 'OFF' or lowest setting. The burner will turn 'OFF' immediately, but fans will continue to cool heat exchanger until the fan thermostat switches off.

**IF THE HEATER WILL NOT OPERATE, TO ENSURE YOUR SAFETY, FOLLOW THESE INSTRUCTIONS TO SHUT DOWN YOUR HEATER**

1. Set the thermostat to off or the lowest setting.
2. Turn off electric power to the heater.
3. Turn off the manual gas valve in the heater supply line.
4. Call your installer/contractor qualified in the installation and service of gas-fired heating equipment.

**WARNING**



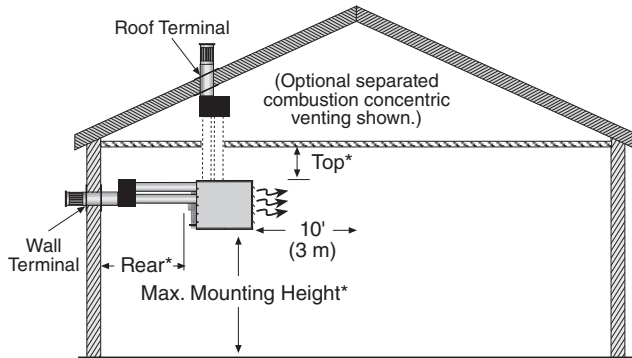
**Fire Hazard**

Some objects can catch fire or explode when placed close to heater.

Keep all flammable objects, liquids and vapors the required clearances to combustibles away from heater.

Failure to follow these instructions can result in death, injury or property damage.

**Installation Clearances**

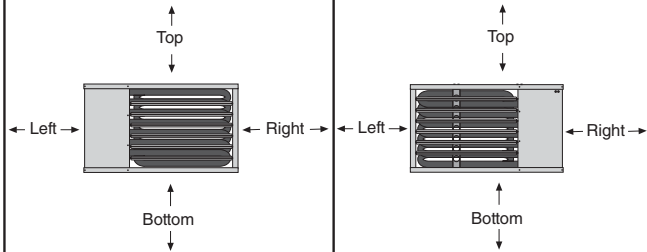


*Models	30 - 125	150 - 400
Top	1" (2.5 cm)	6" (15 cm)
Rear	18" (46 cm)	24" (61 cm)
Max Mounting Height <sup>1</sup>	12' (3.7 m) - 20' (6 m)	20' (6 m) - 30' (9 m)

<sup>1</sup>Heaters can be mounted higher if destratification fans are installed. See Installation, Operation and Service Manual for specific mounting height recommendations.

NOTE: Venting directly from top of heater not applicable on Models 150-400.

**Clearances to Combustibles**



**Models 30 - 125**

**Models 150 - 400**

Models	30 - 125	150 - 400
Top	1" (2.5 cm)	6" (15 cm)
Bottom	0" (0 cm)	3" (8 cm)
Right	1" (2.5 cm)	31" (79 cm)*
Left	18" (46 cm)*	6" (15 cm)
Vent	2" (5 cm)	2" (5 cm)

\* Clearance needed for servicing.

**Roberts-Gordon, LLC**

1250 William Street  
P.O. Box 44  
Buffalo, NY 14240-0044 USA

Telephone: 716.852.4400  
Fax: 716.852.0854  
Toll Free: 800.828.7450

**Installation Code and Annual Inspections:**

All installations and service of ROBERTS GORDON® equipment must be performed by a contractor qualified in the installation and service of equipment sold and supplied by Roberts-Gordon and conform to all requirements set forth in the ROBERTS GORDON® manuals and all applicable governmental authorities pertaining to the installation, service and operation of the equipment. To help facilitate optimum performance and safety, Roberts-Gordon recommends that a qualified contractor annually inspect your ROBERTS GORDON® equipment and perform service where necessary, using only replacement parts sold and supplied by Roberts-Gordon.

For installations at elevations above 2000' (610 m), the appliance shall be derated 4% for each 1000' (305 m) of elevation above sea level.

**Further Information:** Applications, engineering and detailed guidance on systems design, installation and equipment performance is available through ROBERTS GORDON® representatives. Please contact us for any further information you may require, including the Installation, Operation and Service Manual.

**Models 100-400 are not for residential use.**